

# TM 10-4320-202-25P

DEPARTMENT OF THE ARMY TECHNICAL MANUAL

---

ORGANIZATIONAL, DIRECT AND GENERAL SUPPORT,  
AND DEPOT MAINTENANCE REPAIR PARTS  
AND SPECIAL TOOLS LISTS

PUMPING ASSEMBLY, FLAMMABLE LIQUID,  
BULK TRANSFER, 50 GPM (BARNES MODEL 9117CA)

ARMY MODEL SPE 16

FSN 4320-728-0265

(BARNES MODEL 15671CA) ARMY MODEL SPE16A

FSN 4320-658-2888

(BARNES MODEL 4074CA)

FSN 4320-271-1858

---

This copy is a reprint which includes current  
pages from Change 1.

HEADQUARTERS, DEPARTMENT OF THE ARMY

APRIL 1967



CHANGE }  
 No. 1 }

HEADQUARTERS  
 DEPARTMENT OF THE ARMY  
 WASHINGTON, D.C., 11 February 1969

Organizational, Direct and General Support,  
 and Depot Maintenance Repair Parts and  
 Special Tools Lists  
 PUMPING ASSEMBLY, FLAMMABLE LIQUID,  
 BULK TRANSFER, 50GPM (BARNESMODEL9117CA)  
 (ARMY MODEL SPE 16) FSN 4320-728-0265  
 (BARNES MODEL 15671CA) (ARMY MODEL SPE 16A)  
 FSN 4320-658-2888 (BARNES MODEL 4074CA) FSN 4320-271-1858

TM 10-4320-202-25P, 4 April 1967, is changed as follows:

Page v. Paragraph 7 is superseded as follows:

**7. Reporting of Equipment Publication  
 Improvements**

Reporting of errors, omissions, and recommendations for improving this publication by the individual user is encouraged. Reports should be

submitted on DA Form 2028 (Recommended Changes, to DA Publications) and forwarded direct to the Commanding General, U. S. Army Mobility Equipment Command, ATTN: AMSME-MPP, 4300 Goodfellow Boulevard, St. Louis, Mo. 63120.

Page vi. In Section II Prescribed Load Allowance, Group 0100 — ENGINE ASSEMBLY, change FSN in column 1 from 2805-368-6824 to 2805-347-1748.

Group 0304 — AIR CLEANER, change FSN in column 1 from 2940-012-0587 to 2940-021-0587.

Group 0605 — IGNITION COMPONENTS, change FSN in column 1 from 5910-321-7541 to 5910-189-5518. Change manufacturer's 5 digit code from 21387 to 82796.

Page vii. Change Functional, Group 065 — IGNITION COMPONENTS to read Group 0605 — IGNITION COMPONENTS.

Group 0605 — IGNITION COMPONENTS. Delete the following line; 2920-620-0291, CABLE ASSEMBLY, Special Purpose, Electrical: spark plug (66289) RD259.

Change FSN in column 1 from 2920-509-9612 to 2920-293-5212. Change manufacturer's 5 digit code from (66289) to (96906). Change part number from YD171 to MS35911-11.

Group 5500 — PUMP ASSEMBLY, change FSN in column 1 from 4320-360-0594 to 4320-360-0599.

Group 5501 — SHAFT, ROTOR, IMPELLERS, change FSN in column 1 from 4340-360-0598 to 4320-360-0598.

Group 5505 — SUCTION AND/OR DISCHARGE ASSEMBLY, change FSN in column 1 from 4930-624-4850 to 4930-904-1383. Change part number from H707 to H4126.

Group 5510 - INLET AND OUTLET COMPONENTS, change FSN in column 1 from 4320-360-0591 to 4730-360-0591.

Change FSN in column 1 from 4320-360-0595 to 4730-360-0595.

*Page viii.* Group 5510 - INLET AND OUTLET COMPONENTS, change FSN in column 1 from 5340-816-4368 to 4320-360-0593. Add asterisks to Column (A) and (B). Add 2 to column (C) and (D).

Group 9501 - HARDWARE SUPPLIES AND BULK MATERIAL, COMMON, change column 3D Allowances to read 2 instead of 4 on Wire, FSN 6145-519-2833.

All changes, additions and deletions of Federal stock numbers or manufacturer's part numbers within these changes should be appropriately reflected in the index.

All changes, additions, and deletions are shown on the following pages:

PAGE	LINE	(1) ACTION	(2) FEDERAL STOCK NUMBER	(3) DESCRIPTION	(4) UNIT OF ISSUE	(5) QUANTITY INCORPOR- ATED IN UNIT PACK	(6) QUANTITY INCORPOR- ATED IN UNIT	(7) 15-DAY ORGANIZATIONAL MAINT. ALLOWANCES				(8) ILLUSTRATIONS (A) (B) FIGURE ITEM NO. OR FIGURE NO.				
								(A)	(B)	(C)	(D)	(A)	(B)			
				SECTION III-REPAIR PARTS FOR ORGANIZATIONAL MAINTENANCE												
1	0004	CH COL 2	28347-1748	0100-ENGINE ASSEMBLY GASKET SET*** 66289Q2												
	0023	CH COL 3	2805-351-6835	0101-CRANKCASE,BLOCK, CYLINDER HEAD GASKET: CYLINDER HEAD (COMPONENT OF GASKET SET, STOCK NO. 2805-347-1748, SEE GROUP 0100) 7430QD604A												
2	0108	CH COL 3	5330-239-1471	0301-CARBURETOR GASKET:CARBURETOR FLANGE (COMPONENT OF GASKET SET, STOCK NO. 2805-347-1748,SEE GROUP 0100 66289QC53												
4	0192	CH CODE NO.IN COL 3	5910-189-5518	0605-INGINITION COMPONENTS CAPACITOR*** 82796SXY2433												
5	0212	CH COL 3	2920-047-4530	GASKET:MAGNETO FLANGE (COMPONENT OF GASKET SET,STOCK NO. 2805-347-1748, SEE GROUP 0100) 66289QD570A												
	0213	CH COL 2 AND CODE AND PART NO. IN COL 3	2920-293-5212	SPARK PLUG*** 96906MS35911-11 5510-INLET AND OUTLET COMPONENTS												
7	0281	CH COL 2 AND CODE AND PART NO.IN COL 3	4730-360-0591	COUPLING HALF*** 96906MS27025-9												
	0282	CH COL 2 AND CODE AND PART NO. IN COL 3	4730-360-0595	GASKET*** 96906MS27020-5 9501-HARDWARE SUPPLIES AND BULK MATERIAL,COMMON												
	0304	CH COL 7D	6145-519-2833	WIRE*** 0574815876												

2

PAGE	LINE	ACTION	(1) FEDERAL STOCK NUMBER	(2) DESCRIPTION	(3)	(4)	(5)	(6)	(7)	(8)	(9)	(10)
						UNIT OF ISSUE	QUANTITY INCORPOR- ATED IN UNIT PACK	QUANTITY INCORPOR- ATED IN UNIT	30-DAY DS/GS MAINT. ALLOWANCES	1-20	21-50	51-100
				SECTION V--REPAIR PARTS FOR DS.GS.AND DEPOT MAINTENANCE								
				0100-ENGINE ASSEMBLY								
9	0004	CH COL 2	2805-347-1748	GASKET SET*** 66289Q2 0101-CRANKCASE,BLOCK, CYLINDER HEAD								
	0023	CH COL 3	2805-351-6835	GASKET:CYLINDER HEAD (COMPONENT OF GASKET SET, STOCK NO. 2805-347-1748 SEE GROUP 0100)								
	0024	CH COL 3	2805-376-0398	74340QD604A GASKET:ENGINE BASE (COMPONENT OF GASKET SET STOCK NO. 2805-347-1748 SEE GROUP 0100)								
				66289QD569A								
10	0042	CH COL 3	2805-244-8184	0102-CRANKSHAFT GASKET:BEARING PLATE, FLYWHEEL END (COMPONENT OF GASKET SET, STOCK NO.2805-347-1748 SEE GROUP 0100)								
	0043	CH COL 3	5330-266-2701	66289QD574 GASKET:MAIN BEARING PLATE, TAKE-OFF END (COMPONENT OF GASKET SET, STOCK NO.2805-347-1748 SEE GROUP 0100)								
	0044	CH COL 3	5330-298-5170	66289QD573 GASKET:MAIN BEARING PLATE, TAKE-OFF END (COMPONENT OF GASKET SET STOCK NO. 2805-347-1748, SEE GROUP 0100)								
				66289QD573A								

(1)	(2)	(3)	(4)	(5)	(6)	(7)	(8)	(9)	(10)
PAGE	LINE	ACTION	FEDERAL STOCK NUMBER	DESCRIPTION	UNIT OF ISSUE	QUANTITY INCORPORATED IN UNIT PACK	QUANTITY INCORPORATED IN UNIT	30-DAY DS/GS MAINT. ALLOWANCES	1 YEAR ALLOWANCE PER 100 MAINT. EQUIPMENT ALLOWANCES CONTING PER 100 FIGURE PLANNING EQUIPMENT NO. PURPOSES
				0105-VALVES, CAMSHAFTS AND TIMING SYSTEM				1-20 21-50 51-100	
11	0064	CH COL 3	2805-268-3448	GASKET:VALVE CHAMBER INSPECTION PLATE (COMPONENT OF GASKET SET, STOCK NOJ 2805-347-1748, SEE GROUP 0100) 66289QD572					
12	0108	CH COL 3	5330-239-1471	0301-CARBURETOR GASKET:CARBURETOR FLANGE (COMPONENT OF GASKET SET, STOCK NO.2805-347-1748, SEE GROUP 0100) 66289QC53					
13	0139	CH COL 3	5330-285-5061	0308-ENGINE SPEED GOVERNOR AND CONTROLS					
15	0192	CH CODE NO. IN COL 3.	5910-189-5518	GASKET:GOVERNOR YOKE SHAFT BRACKET (COMPONENT OF GASKET SET, STOCK NO.2805-347-1748, SEE GROUP 0100) 66289QD571					
	0212	CH COL 3	2920-047-4530	0605-IGNITION COMPONENTS CAPACITOR*** 82796SXY2433					
0213	CH COL 2, CH CODE AND PART NO. IN COL 3.	SEE GROUP 0100)	2920-293-5212	GASKET:MAGNETO FLANGE (COMPONENT OF GASKET SET, STOCK NO.2805-347-1748, 66289QD570A SPARK PLUG*** 96906MS35911-11					
18	0281	CH COL 2	4730-360-0591	5510-INLET AND OUTLET COMPONENTS					
	0282	CH COL 2	4730-360-0595	COUPLING HALF*** 81718633C11-2 GASKET*** 81718H6430M					

By Order of the Secretary of the Army:

**W. C. WESTMORELAND,**  
*General, United States Army,*  
*Chief of Staff.*

Official:

**KENNETH G. WICKHAM,**  
*Major General, United States Army,*  
*The Adjutant General.*

**Distribution:**

To be distributed in accordance with DA Form 12-25, Section I, (qty rqr block No. 246) organizational maintenance requirements for Pumps, Centrifugal: Petroleum.



**Organizational, Direct And General Support, And Depot  
Maintenance Repair Parts And Special Tools Lists  
PUMPING ASSEMBLY, FLAMMABLE LIQUID, BULK  
TRANSFER, 50 GPM BARNES MODEL 9117CA, ARMY  
MODEL SPE16, FSN 4320-728-0265 BARNES MODEL  
15671CA, ARMY MODEL SPE16A, FSN 4320-658-2888  
BARNES MODEL 4074CA, FSN 4320-271-1858**

SECTION	Paragraph	Page
<b>I. INTRODUCTION</b>		
Scope .....	1	iii
General .....	2	iii
Explanation of columns .....	3	iii
Instructions for locating repair parts .....	4	v
Abbreviations .....	5	v
Index of Federal supply codes .....	6	v
Reporting of equipment publication improvements .....	7	v
<b>II. PRESCRIBED LOAD ALLOWANCE .....</b>		
<b>III. REPAIR PARTS FOR ORGANIZATIONAL MAINTENANCE</b>		
<b>Group 01. Engine</b>		
0100 Engine assembly .....		1
0101 Crankcase, block, cylinder head .....		1
0105 Valves, camshaft, and timing system .....		1
0107 Engine starting system .....		2
<b>03. Fuel System</b>		
0301 Carburetor .....		2
0304 Air cleaner .....		2
0306 Tanks, lines, fittings .....		2
0308 Engine speed governor and controls .....		3
0309 Fuel filter .....		3
<b>04. Exhaust System</b>		
0401 Muffler and pipes .....		3
<b>05. Cooling System</b>		
0502 Shrouds .....		4
<b>06. Electrical System</b>		
0605 Ignition components .....		4
<b>22. Body, Chassis or Hull and Accessory Items</b>		
2202 Accessory items .....		5
<b>55. Pumps</b>		
5500 Pump assembly .....		6
5501 Shaft, rotors, impellers .....		6
5505 Suction and/or discharge assembly .....		6
5510 Inlet and outlet components .....		7
5511 Coupling .....		7

\*This manual supersedes TM 10-4320-202-20P 23 March 1963 and TM 10-4320-202-35P 27 March 1963.

Group 95. General Use Standardized Parts	
9501 Hardware supplies and bulk material, common .....	7
SECTION IV. SPECIAL TOOLS, TEST AND SUPPORT EQUIPMENT FOR ORGANIZATIONAL MAINTENANCE	
Group 26. Tools and Test Equipment	
2604 Special tools .....	8
SECTION V. REPAIR PARTS FOR DS, GS, AND DEPOT MAINTENANCE	
Group 01. Engine	
0100 Engine assembly .....	9
0101 Crankcase, block, cylinder head .....	9
0102 Crankshaft .....	10
0103 Flywheel assembly .....	10
0104 Pistons, connecting rods .....	11
0105 Valves, camshaft, and timing system .....	11
0106 Engine lubrication system .....	11
0107 Engine starting system .....	12
03. Fuel System	
0301 Carburetor .....	12
0304 Air cleaner .....	12
0306 Tanks, lines, fittings .....	13
0308 Engine speed governor and controls .....	13
0309 Fuel filter .....	14
04. Exhaust system	
0401 Muffler and pipes .....	14
05. Cooling System	
0502 Shrouds .....	15
06. Electrical System	
0605 Ignition components .....	15
22. Body, Chassis or Hull and Accessory Items	
2202 Accessory items .....	16
55. Pumps	
5500 Pump assembly .....	16
5501 Shaft, rotors, impellers .....	17
5505 Suction and/or discharge assembly .....	17
5510 Inlet and outlet components .....	17
5511 Coupling .....	18
95. General Use Standardized Parts	
9501 Hardware supplies and bulk material, common .....	18
SECTION VI. SPECIAL TOOLS, TEST AND SUPPORT EQUIPMENT FOR DS, GS, AND DEPOT MAINTENANCE	
Group 26. Tools and Test Equipment	
2604 Special tools .....	19
SECTION VII. FEDERAL STOCK NUMBER AND PARTS NUMBER INDEX .....	30

## SECTION I

### INTRODUCTION

---

#### 1. Scope

This manual contains a list of repair parts, and special tools, required for the performance of organizational, direct support, general support, and depot maintenance of the pumping assembly.

#### 2. General

This repair parts and special tools list is divided into seven principal sections.

a. Section II, Prescribed Load Allowance List (PLA), is a consolidated listing of repair parts quantitatively allocated for initial stockage at the organizational level. *This is a mandatory minimum stockage allowance.*

b. Section III, Repair Parts List, is a list of repair parts authorized for the performance of maintenance at the organizational level.

c. Section IV, Special Tools, Test and Support Equipment List, is a list of special tools, test and support equipment authorized for the performance of maintenance at the organizational level.

d. Section V, Repair Parts List, is a list of repair parts authorized for the performance of maintenance at the direct support, general support, and depot level.

e. Section VI, Special Tools, Test and Support Equipment List is a list of special tools, test and support equipment authorized for the performance of maintenance at direct support, general support, and depot level.

f. Section VII, Federal Stock Number and Manufacturer's Part Number Index, is an index of Federal stock numbers and manufacturer's part numbers to page and manufacturer's codes.

#### 3. Explanation of Columns

The following provides an explanation of columns in the tabular lists.

a. Source, Maintenance, and Recoverability Codes.

- (1) Source Code indicates the selection status and source for the listed item. Source codes used are:

<i>Code</i>	<i>Explanation</i>
P	Applied to repair parts which are stocked in or supplied from DSA/GSA or Army supply system, and authorized for use at indicated maintenance categories.
M	Applied to repair parts which are not procured or stocked, but are to be manufactured at indicated maintenance categories.
A	Applied to assemblies which are not procured or stocked as such but made up of two or more units, each of which carry individual stock numbers and descriptions and are procured and stocked and can be assembled by units at indicated maintenance categories.
X	Applied to parts and assemblies which are not procured or stocked, the mortality of which is normally below that of the applicable end item, and the failure of which should result in retirement of the end item from the supply system.
X 1	Applied to repair parts which are not procured or stocked, the requirement for which will be supplied by use of the next higher assembly or components.
X 2	Applied to repair parts which are not stocked. The indicated maintenance category requiring such repair parts will attempt to obtain them through cannibalization; if not obtainable through cannibalization, such repair parts will be requisitioned with supporting justification through normal supply channels.

*Note.* Source code is not shown on common hardware items known to be readily available in Army supply channels and through local procurement.

- (2) Maintenance Code indicates the lowest category of maintenance authorized to maintain the listed item. The maintenance level codes are:

Code	Explanation
O	Organizational maintenance
F	Direct support maintenance
H	General support maintenance
D	Depot maintenance

- (3) Recoverability Code indicates whether unserviceable items should be returned for recovery or salvage. Items not coded are expendable. The recoverability code is:

Code	Explanation
R	Applied to repair parts and assemblies which are economically repairable at DSU and GSU activities and normally are furnished by supply on an exchange basis.

*b.* Federal Stock Number indicates the Federal stock number for the item.

*c.* Description column indicates the Federal item name and brief description of the item. A five-digit manufacturer's or other service code is shown in parentheses followed by the manufacturer's part number. Repair parts quantities included in kits, sets, and assemblies that differ from the actual quantity used in the specific item, are listed in parentheses following the repair part name.

*d.* Unit of Issue indicates the unit used as a basis of issue, e.g., ea, pr, ft, yd, etc.

*e.* Quantity Incorporated in Unit Pack indicates the actual quantity contained in the unit pack.

*f.* Quantity Incorporated in Unit indicates the actual number of parts used in the application. A zero is shown when components of kits or sets are listed that are not applicable to the specific end item.

*g.* Fifteen-Day Organizational Maintenance Allowance.

- (1) The allowance columns are divided into four subcolumns. Indicated in each subcolumn is the quantity of items authorized for the number of equipments supported. Items authorized for use as required but not for initial

stockage are identified with an asterisk in the allowance column.

- (2) The quantitative allowances for organizational level of maintenance represents one initial prescribed load for a 15-day period for the number of equipments supported. Units and organizations authorized additional prescribed loads will multiply the number of prescribed loads authorized by the quantity of repair parts reflected in the appropriate density column to obtain the total quantity of repair parts authorized.
- (3) Items identified by an asterisk may be requisitioned as required. Subsequent changes and/or additions to allowances will be limited to the provisions of AR 735-35. The range of items authorized will be made by this Command based upon engineering experience, demand data, or TAERS information.
- (4) Allowances are based on 1,000 hours of operation per year.

*h.* Thirty-Day DS/GS Maintenance Allowance.

- (1) The allowance columns are divided into three subcolumns. Indicated in each subcolumn is the quantity of items authorized for a number of equipments supported. Items authorized for use as required but not for initial stockage are identified with an asterisk in the allowance column.
- (2) The quantitative allowances for DS/GS levels of maintenance will represent initial stockage for a 30day period for the number of equipments supported.

*i.* One-Year Allowances Per Equipments/Contingency Planning Purposes indicates the quantity of items required for distribution and contingency planning purposes.

*j.* Depot Maintenance Allowance Per 100 Equipments indicates the total quantity of items recommended for depot maintenance of 100 equipments. Items recommended for immediate use only are identified with an asterisk in the allowance column.

k. Illustration.

- (1) Figure Number indicates the figure number of the illustration in which the item is shown.
- (2) Item or Symbol Number indicates the callout number used to reference the item in the illustration.

4. Instructions for Locating Repair Parts

a. When Federal Stock Number or manufacturer's part number is unknown.

- (1) *First.* Using the index of contents, determine the functional group or subgroup, i.e., engine, engine assembly, transmission, transmission assembly, within which the repair part belongs. Locate the appropriate page in the manual and identify the part.
- (2) *Second.* Locate the repair part and the illustration figure and item number as shown in the last two columns of the repair parts listing.
- (3) *Third.* Identify the repair part on the illustration.

b. When Federal Stock Number or manufacturer's part number is known.

- (1) *First.* Use the index to locate the Federal stock number or manufacturer's part number. This index is arranged in alphameric sequence cross-referenced to page number and manufacturer's code.
- (2) *Second.* Refer to the appropriate page in the parts listing. Locate the repair part and the illustration figure and item number as shown in the last two columns of the parts listing.

5. Abbreviation

c/o \_\_\_\_\_ consist(s) of  
 ea \_\_\_\_\_ each  
 FSN \_\_\_\_\_ Federal stock number

ft ----- foot (feet)  
 in. \_\_\_\_\_ inch (es)  
 mm ----- millimeter(s)  
 mtg \_\_\_\_\_ mounting(s)  
 No. \_\_\_\_\_ number(s)  
 sq \_\_\_\_\_ square  
 thk \_\_\_\_\_ thick (ness)  
 u/o \_\_\_\_\_ used on  
 w/ \_\_\_\_\_ with  
 w/o \_\_\_\_\_ without

6. Index of Federal Supply Codes

Code	Manufacturer
00000	Ordnance Corp.
01400	United Mfg. and Eng. Corp.
05748	Barnes Mfg. Co.
10001	Bureau of Naval Weapons
12505	Hungerford Plastics Corp.
21387	Fairbanks Morse and Co.
24617	General Motors Corp.
43999	North American Aviation Inc.
60038	Timken Roller Bearing Co.
63686	Walworth Co.
66289	Wisconsin Motor Corp.
74340	Highway Trailer Industries Inc.
76700	Nelson Muffler Corp.
77414	Punch Lok Co.
78480	Tillotson Mfg. Co., The
79150	Victor Mfg. and Gasket Co.
80749	United Specialties Co.
81718	OPW Corp.
82796	Fairbanks Morse and Co.
96152	Marvel Schebler Products Div. of Borg-Warner Corp.
96906	Dept. of Defense Military Standards

7. Reporting of Equipment Publication Improvements

DA Form 2028 (Recommended changes to DA publications) will be used for reporting discrepancies and recommendations for improving this equipment publication. This form will be completed by the individual using the manual and forwarded direct to Commanding General, U. S. Army Mobility Command, ATTN: AMSME-MPD, 4300 Goodfellow Blvd. St. Louis, Mo. 63120.

SECTION II

PRESCRIBED LOAD ALLOWANCE

(1) FEDERAL STOCK NO.	(2) DESCRIPTION	(3) 15-DAY ORG MAINT ALW			
		(A) 1-5	(B) 6-20	(C) 21-50	(D) 51-100
SECTION II-REPAIR PARTS LIST					
0100-ENGINE ASSEMBLY					
2805-368-6824	GASKET SET: ENGINE OVERHAUL (66289) Q2	*	*	2	2
0301-CARBURETOR					
2910-255-2308	CARBURETOR, FLOAT (96152) VH53	*	2	3	5
0304-AIR CLEANER					
2940-012-0587	ELEMENT AIR: AIR W/O BRACKET, CARBURETOR (80749) 76B1	*	*	*	2
2910-447-9260	GASKET: CARBURETOR AIR CLEANER BRACKET (66289) QD647	*	*	2	2
0306-TANKS, LINE, FITTINGS					
2910-672-1916	CAP, FUEL TANK (66289) RC104	*	*	2	2
5330-675-5752	GASKET: CAP (66289) QD694	*	*	2	2
0308-ENGINE SPEED GOVERNOR CONTROLS					
2990-224-8188	SPRING, HELICAL, EXTENSION: GOVERNOR (66289) PM74	*	*	*	2
5340-256-7147	SPRING, HELICAL COMPRESSION: LEVER SUPPORT STUD (66289) PM117	*	*	*	2
0309-FUEL FILTER					
2910-358-4317	BOWL, SEDIMENT: GLASS (78480) 07759	*	2	3	5
2910-282-7557	GASKET: BOWL	4	8	16	34
5330-145-2017	WASHER, NONMETALLIC: SHUT-OFF VALVE (78480) 0705	4	8	16	34
0401-MUFFLER AND PIPES					
4940-672-4767	GASKET SET: ENGINE EXHAUST MUFFLER COUPLER (05748) 16418SA	2	2	4	8
2990-389-6412	MUFFLER, EXHAUST: ENGINE (76700) TI802D	*	*	2	2
0605-IGNITION COMPONENTS					
2920-654-3499	MAGNETO, IGNITION: RADIO SHIELD (21387) FMXDIB7U	*	*	2	2
5910-321-7541	CAPACITOR, FIXED, PAPER DIELECTRIC (21387) SXY2433	*	2	3	5

SECTION II

PRESCRIBED LOAD ALLOWANCE

(1) FEDERAL STOCK NO.	(2) DESCRIPTION	(3) 15-DAY ORG MAINT ALW			
		(A) 1-5	(B) 6-20	(C) 21-50	(D) 51-100
065-IGNITION COMPONENTS-CONTINUED					
5340-675-5753	CLIP,RETAINING: FULCRUM PIN (21387) TI498	*	*	2	2
2920-294-4001	COIL,MAGNETO (82796) D2477A	*	*	2	2
2920-319-5055	CONTACT SET, DISTRUBUTOR (21387) A2437A	2	4	8	17
2920-510-1298	GASKET:END CAP (21387) K2498	2	4	8	17
2920-620-0291	CABLE ASSEMBLY,SPECIAL, ELECTRICAL: SPARK PLUG (66289) YD259	*	*	*	2
2920-620-0291	CABLE ASSEMBLY, SPECIAL PURPOSE, ELECTRICAL: SPARK PLUG (66289) RD 259	*	2	2	5
2920-509-9612	SPARK PLUG:RADIO SHIELDED, 18 MM (66289) YD171	4	8	16	34
5330-467-3553	GASKET: SPARK PLUG, 18 MM SOLID COPPER (79150) 2106A	2	2	4	8
550-PUMP ASSEMBLY					
4320-360-0601	GASKET SET:BODY TO INTERMEDIATE COUPLING C/O THE FOLLOWING ITEMS (05748) 8121SA	*	*	2	2
4320-360-0594	GASKET: SUCTION CHECK VALVE (05748) 8026	*	2	2	3
5501-SHAFT, ROTOR, IMPELLERS					
4340-360-0598	IMPELLER (05748) 8023	*	*	2	2
4320-360-0597	SEAL ASSEMBLY: INTERMEDIATE COUPLING (05748) 8022	*	*	*	2
4320-360-0602	SHIM SET:IMPELLER (05748) 8139SA	*	*	*	2
5505-SUCTION AND/OR DISCHARGE ASSEMBLY					
4320-360-0600	VALVE ASSEMBLY: CHECK,SUCTION (05748) 8117SA	*	*	*	2
4930-360-0569	NOZZLE FUEL AND OIL SERVICING: PRESSURE PUMP DISCHARGE HOSE (81718) CC21011-2	*	*	*	2
4930-624-4850	PARTS KIT, FUEL AND OIL SERVICING: NOZZLE:DISCHARGE HOSE C/O THE FOLLOWING ITEMS (81718) H707	*	*	*	2
4730-360-0571	SPOUT:NOZZLE (81718) 29611-2X5-8	*	*	*	2
4320-360-0596	5510-INLET AND OUTLET COMPONENTS CHAIN: W/S HOOK,PRESSURE PUMP SUCTION AND DISCHARGE 9881718) H6683M	*	*	*	2
4320-360-0591	COUPLING HALF, QUICK DISCOUNT: W/SHANK FEMALE, PRESSURE PUMP DISCHARGE AND SUCTION HOSE (81718) 633C11-2	*	*	*	2
4320-360-0595	GASKET: CAMLOCK TYPE, DISCHARGE AND SUCTION HOSE COUPLER (81718) HM6430M	*	2	2	3
4720-303-4984	HOSE ASSEMBLY: DISCHARGE (05748) 15656SA	*	*	*	2

SECTION II

PRESCRIBED LOAD ALLOWANCE

(1) FEDERAL STOCK NO.	(2) DESCRIPTION	(3) 15-DAY ORG MAINT ALW (A) (B) (C) (D) 1-5 6-20 21-50 51-100			
	5510-INLET AND OUTLET COMPONENTS- CONTINUED				
5340-816-4368	PLUG, PROTECTIVE, DUST: MALE, DUST PRESSURE PUMP DISCHARGE AND SUCTION HOSE COUPLER (81718) 634A11-2				
6145-519-2833	9501-HARDWARE SUPPLIES AND BULK MATERIAL, COMMON WIRE, ELECTRICAL (05748) 15876	*	2	2	4



LINE NO.	(1) SOURCE, MAINT. AND RECOV.			(2) FEDERAL STOCK NUMBER	(3) DESCRIPTION	(4) MANUFACTURER'S CODE PART NUMBER		(5) UNIT OF ISSUE	(6) QTY INC IN UNIT		(7) 15 DAY ORG. MAINT. ALW.				(8) ILLUS-TRATION			
	(A) SOURCE	(B) MAINT.	(C) RECOV.			IN	PACK		1-5	(A) (B)	(C) 21-50	(D) 51-100	(A) FIG. NO.	(B) ITEM OR SYM. NO				
0001					SECTION III - REPAIR PARTS FOR ORGANIZATIONAL MAINTENANCE													
0002					GROUP 01 - ENGINE													
0003					0100 - ENGINE ASSEMBLY													
0004	P	O		2805-397-1748	GASKET SET: ENGINE OVERHAUL	66289	Q2	EA		1	*	*	2	2				
0005	X1			5330-239-1471	GASKET: CARBURETOR FLANGE	66289	QC53	EA		1					SEE GRP 0301			
0006	X1			2805-351-6835	GASKET: CYLINDER HEAD	74340	QD604A	EA		1					SEE GRP 0101			
0008	X1			5330-285-5061	GASKET: GOVERNOR YOKE SHAFT BRACKET	66289	QD571	EA		1								
0009	X1			2920-047-4530	GASKET: MAGNETO FLANGE	66289	QD570A	EA		1					SEEGRP 0605			
0013	X1			2805-244-8184	GASKET: VALVE CHAMBER INSPECTION PLATE	66289	QD574	EA		1								
0014		0		5310-021-0377	PUT, PLAIN, HEXAGON: POWER UNIT MTG	96906	MS35690-605	EA		4	*	*	*	*				
0015	P	O	R	2805-672-1918	POWER UNIT, GASOLINE: READY TO RUN SUPERSEDES FSN 2805-358-2473 ENG LINE ASSEMBLY	66289	BKND162685	EA		1	*	*	*	*				
0016		0		5305-269-3218	SCREW, CAP, HEXAGON HEAD: POWER5 UNIT MTG	24617	180134	EA		4	*	*	*	*				
0017		0		5310-012-0382	WASHER, LOCK: POWER UNIT MTG (81349) FPN.84, CLASS A STYLE A2			EA		4	*	*	*	*				
0018		0		5310-013-8489	WASHER, LOCK: POWER UNIT MTG	81349	MILB6986TYPEA	EA		8	*	*	*	*				
0019					0101- CRANKCASE, BLOCK, CYLINDER HEAD													
0020		0		5306-018-0081	BOLT, MACHINE: HEAD MTG	96906	MS35297-036	EA		5	*	*	*	*	1	1		
0021		0		5306-018-0087	BOLT, MACHINE: HEAD MTG	96906	MS35297-40	EA		3	*	*	*	*	1	2		
0022	X2	0		2805-033-6140	BREATHER: CRANKCASE	66289	L0-31A	EA		1	*	*	*	*				
0023	X1			2805-351-6835	GASKET: CYLINDER HEAD (COMPONENT OF GASKET SET, STOCK NO. 2805-368-6824, SEE GROUP 0100)	74340	QD604A	EA		1					1	6		
0025	X2	0		2805-672-1922	HEAD: CYLINDER	66289	AB99P2	EA		1	*	*	*	*	1	5		
0027		0		4730-042-6318	PLUG, PIPE: CRANKCASE TIMING INSPECTION HOLE	24617	103885	EA		1	*	*	*	*	1	5		
0028	X2	0		4730-021-9199	PLUG, PIPE: CYLINDER OIL FILLER, SQ HEAD, 1/2 IN. (81348) WWP471, TYPE 2, STYLE 2			EA		1	*	*	*	*	1	7		
0029		0		4730-622-1607	PLUG, PIPE, MAGNETIC: ENGINE BASE OIL DRAIN	66289	XK2A	EA		1	*	*	*	*	1	11		
0032		0		5310-616-3023	WASHER, FLAT: HEAD MTG	96906	MS15795-212	EA		7	*	*	*	*	1	4		
0033		0		5310-012-0214	WASHER, LOCK: HEAD MTG	96906	MS35338-26	EA		1	*	*	*	*	1	3		
0062					0105-VALVES, CAMSHAFTS AND TIMING SYSTEM													
0069	X2	0		2805-376-0416	PLATE: VALVE CHAMBER INSPECTION	66289	SA61	EA		1	*	*	*	*	1	26		
0070	X2	0		2805-376-0385	PLUG, BREATHER: VALVE CHAMBER	66289	PF102	EA		1	*	*	*	*				

LINE NO.	(1) SOURCE, MAINT. AND RECOV.			(2) FEDERAL STOCK NUMBER	(3) DESCRIPTION	(4) MANUFACTURER'S		(5) UNIT OF ISSUE	(6) QTY INC		(7) 15 DAY ORG. MAINT. ALW.				(8) ILLUS-TRATION	
	(A) SOURCE	(B) MAINT.	(C) RECOV.			CODE	PART NUMBER		IN	PACK	IN	UNIT	(A) 1-5	(B) 6-20	(C) 21-50	(D) 51-100
0072		0		5305-071-2239	SCREW, CAP, HEXAGON HEAD: INSPECTION PLATE MTG	96906	MS90725-12	EA		1	*	*	*	*	1	15
0077		0		5310-285-8538	WASHER, FLAT: INSPECTION PLATE MTG	66289	PH30	EA		1	*	*	*	*	1	14
0092					0107 - ENGINE STARTING SYSTEM											
0093	X2	0		2990-422-6161	PULLEY, ENGINE STARTER ROPE	66289	UC103A	EA		1	*	*	*	*	5	2
0094	P	0		2990-142-0080	STARTER ROPE, ENGINE	66289	U218A	EA		1	*	*	*	*	5	4
0095	X2	0		5310-013-8502	WASHER, LOCK: PULLEY MTG	96906	MS35335-25	EA		1	*	*	*	*	5	3
0096					GROUP 03 - FUEL SYSTEM											
0097					0301-CARBURETOR											
0098	P	0		2910-255-2308	CARBURETOR, FLOAT	96152	VH53	EA		1	*	2	3	5	1	24
0104		0		5310-012-0367	NUT, PLAIN, HEXAGON: CARBURETOR MTG	96906	MS35690-425	EA		2	*	*	*	*	1	25
0105	P	0		5330-238-7951	PACKING: METER NEEDLE	96152	44-51	EA		1	*	*	*	*		
0106		0		5307-286-0334	STUD, PLAIN: CARBURETOR MTG	66289	PC368	EA		2	*	*	*	*	1	29
0108	X1			5330-239-1471	GASKET: CARBURETOR FLANGE (COMPONENT OF GASKET SET, STOCK NO. 2805-348-6824, SEE GROUP 0100)	66289	QC53	EA		1					1	27
0109					0304 - AIR CLEANER											
0110	X2	0		2940-675-5751	BRACKET ASSEMBLY: CARBURETOR AIR CLEANER	66289	B1264BS1	EA		1	*	*	*	*	1	21
0111	P	0		2940-021-0587	ELEMENT AIR: W/O BRACKET, CARBURETOR	80749	76B1	EA		1	*	*	*	2	1	19
0112	P	0		2910-447-9260	GASKET: CARBURETOR AIR CLEANER BRACKET	66289	QD647	EA		1	*	*	2	2		
0113		0		5305-068-0502	SCREW, CAP, HEXAGON HEAD: STRAP MTG	81336	180020	EA		1	*	*	*	*	1	16
0114		0		5305-988-1727	SCREW, MACHINE: BRACKET MTG	96906	MS35206-283	EA		1	*	*	*	*	1	22
0115		0		5305-011-5137	SCREW, TAPPING, THREAD FORMING: ELEMENT TO BRACKET MTG	81336	115137	EA		3	*	*	*	*	1	20
0116	X2	0		2940-215-7226	STRAP: CARBURETOR AIR CLEANER BRACKET SUPPORT	66289	PG287	EA		1	*	*	*	*	1	18
0117		0		5310-809-4058	WASHER, FLAT: STRAP MTG	96906	MS15795-210	EA		1	*	*	*	*	1	23
0119					0306 - TANKS, LINES, FITTINGS											
0120	X2	0		2910-464-3530	BRACKET: FUEL TANK	66289	BK71	EA		1	*	*	*	*		
0121	P	0		2910-672-1916	CAP, FUEL TANK	66289	RC104	EA		1	*	*	2	2	7	2
0122	P	0		4730-231-5632	ELBOW, PIPE TO TUBE: BRASS, CARBURETOR FUEL	24617	118753	EA		2	*	*	*	*		
0123	P	0		5330-675-5752	GASKET: CAP	66289	QD694	EA		1	*	*	2	2		
0124		0		5310-176-8139	NUT, PLAIN, HEXAGON	19315	205-01-17	EA		2	*	*	*	*		
0126		0		5305-267-3209	SCREW, CAP, HEXAGON HEAD	96906	MS90725-28	EA		2	*	*	*	*		
0127		0		5305-988-9265	SCREW, MACHINE	96906	MS35206-286	EA		2	*	*	*	*		
0128	X2	0		2910-672-1914	STRAP: FUEL TANK	66289	PG733	EA		2	*	*	*	*		

LINE NO.	(1) SOURCE, MAINT. AND RECOV.			(2) FEDERAL STOCK NUMBER	(3) DESCRIPTION	(4)		(5)		(6)				(7)		(8) ILLUS- TRATION	
	(A) SOURCE	(B) MAINT.	(C) RECOV.			MANUFACTURER'S CODE	UNIT OF ISSUE	QTY IN	INC PACK	QTY IN	INC UNIT	15 DAY MAINT.	ORG. ALW. (B)	(C)	(D)	(A) FIG. NO.	(B) ITEM OR SYM. NO
0129	X2	0		2910-672-1915	TANK ASSEMBLY: W/CAP, FUEL	66289	WE14G	EA		1	*	*	*	*	7	1	
0130		0		5310-012-0382	WASHER, LOCK	24617	120382	EA		2	*	*	*	*			
0131		0		5310-582-5965	WASHER, LOCK	96906	MS35338-044	EA		2	*	*	*	*			
0133					0308 - ENGINE S[PEED GOVERNOR AND CONTROLS												
0135		0		5306-356-0965	BOLT, HOOK: GOVERNOR CONTROL	66289	VE304	EA		1	*	*	*	*	3	19	
0137	X2	0		2990-383-9339	CONTROL ASSEMBLY: SPEED	66289	VE363A	EA		1	*	*	*	*	6	13	
0140	X2	0		2990-301-6374	LEVER: GOVERNOR CONTROL	66289	TC332	EA		1	*	*	*	*	3	21	
0141		0		5310-012-0367	NUT, PLAIN, HEXAGON	96906	MS35690-425	EA		1	*	*	*	*	3	2	
0142		0		5315-828-8190	PIN, COTTER: GOVERNOR CONTROL	96906	MS24665-69	EA		1*	*	*	*	*	3	20	
0147	P	0		2990-224-8188	SPRING, HELICAL, EXTENSION: GOVERNOR	66289	PM74	EA		1	*	*	*	2	3	22	
0149	X2	0		2990-536-2962	BLOCK: SPRING ADJUSTING SCREW	66289	TC301-3	EA		1	*	*	*	*	6	2	
0150		0		5310-833-2080	NUT, PLAIN, HEXAGON: BLOCK MTG	96906	MS35650-101	EA		2	*	*	*	*	6	1	
0151		0		5315-252-5989	PIN, COTTER: SPEED CONTROL	81348	FFP386TYPEB	EA		1	*	*	*	*	6	4	
0152		0		5315-265-9197	PIN, STRAIGHT, HEADLESS: LEVER	66289	PC393-2	EA		1	*	*	*	*	6	7	
0153		0		5315-383-9335	PIN, STRAIGHT, THREADED: SPRING	66289	P1121	EA		1	*	*	*	*	6	3	
0154	P	0		5340-256-7147	SPRING, HELICAL, COMPRESSION: LEVER SUPPORT STUD	66289	PM117	EA		1	*	*	*	2	6	6	
0155		0		5310-809-4058	WASHER, FLAT: SPEED CONTROL	96906	MS15795-210	EA		1	*	*	*	*	6	5	
0156		0		5310-082-1404	WASHER, LOCK: BLOCK TO CONTROL MTG	96906	MS27183-6	EA		1	*	*	*	*	6	14	
0157		0		5310-012-0622	NUT, PLAIN, HEXAGON: SPEED CONTROL			EA		1	*	*	*	*	6	11	
0158		0		5305-012-0585	SCREW, MACHINE: SPEED CONTROL	81366	120585	EA		1	*	*	*	*	6	8	
0159		0		5305-013-2764	SCREW, MACHINE: SPEED CONTROL	81366	132764	EA		1	*	*	*	*	6	12	
0160		0		5310-193-7407	WASHER, FLAT: LEAD, BRACKET SCREW	66289	PH221	EA		2	*	*	*	*	6	10	
0161		0		5310-013-8604	WASHER, LOCK: SPEED CONTROL	08315	8630-29-24	EA		1	*	*	*	*	6	9	
0162					0309 - FUEL FILTER												
0163	P	0		4730-230-1996	NIPPLE, PIPE: BRASS, FUEL STRAINER	24617	142868	EA		1	*	*	*	*			
0164	P	0		4730-639-9638	STRAINER, SEDIMENT: FUEL	78480	OW480T	EA		1	*	*	*	*	7	16	
0165	X2	0		2910-358-4316	BALL	78480	07766	EA		1	*	*	*	*			
0166	P	0		2910-358-4317	BOWL, SEDIMENT: GLASS	78480	07759	EA		1	*	2	3	5			
0167	P	0		2910-282-7557	GASKET: BOWL	78480	08227	EA		1	4	8	16	34			
0168	P	0		2910-358-5327	STRAINER ELEMENT, SEDIMENT	78480	07762	EA		1	*	*	*	*			
0169	P	0		5330-145-2017	WASHER, NONMETALLIC: SHUT-OFF VALVE	78480	0705	EA		1	4	8	16	34			
0170					GROUP 04 - EXHAUST SYSTEM												
0171					0401 - MUFFLER AND PIPES												
0172	P	0		4940-672-4768	ADAPTER: MALE, ENGINE EXHAUST NIPPLE, FEMALE THREAD	81718	633A1	EA		1	*	*	*	*			
0173	P	0		4730-193-6992	BEND, PIPE, RETURN: ENGINE EXHAUST MUFFLER	00000	179504	EA		1	*	*	*	*			

LINE NO.	(1) SOURCE, MAINT. AND RECOV.			(2) FEDERAL STOCK NUMBER	(3) DESCRIPTION	(4) MANUFACTURER'S CODE PART NUMBER	(5) UNIT OF ISSUE	(6) QTY INC		(7) 15 DAY ORG. MAINT. ALW.				(8) ILLUS-TRATION	
	(A) SOURCE	(B) MAINT.	(C) RECOV.					IN	PACK	IN	UNIT	(A) 1-5	(B) 6-20	(C) 21-50	(D) 51-100
0174	P	0		5306-672-1923	BOLT, U: MUFFLER AND EXHAUST ASSEMBLY MTG BRACKET	05748 15664	EA		1	*	*	*	*		
0175	P	0		4940-672-4769	COUPLER PIPE: FEMALE, ENGINE EXHASUT	81718 633D1	EA		1	*	*	*	*		
0176		0		4730-246-1219	MUFFLER FEMALE THREAD	24617 108687	EA		1	*	*	*	*		
0177	P	0		4940-672-4767	ELBOW, PIPE: STREET, ENGINE EXHAUST GASKET SET: ENGINE EXHAUST MUFFLER COUPLER	05748 16418SA	EA		1	2	2	4	8		
0178	P	0		2990-389-6412	MUFFLER, EXHAUST: ENGINE	76700 T1802D	EA		1	*	*	2	2		
0179		0		4730-021-9678	NIPPLE, PIPE: ENGINE EXHAUST	24617 219678	EA		1	*	*	*	*		
0180		0		5310-176-8139	NUT, PLAIN, HEXAGON	19315 20501-17	EA		4	*	*	*	*		
0181		0		5305-225-3839	SCREW, CAP, HEXAGON HEAD: EXHAUST										
0182		0		5310-582-5965	NIPPLE BRACKET	96906 MS90725-8	EA		4	*	*	*	*		
					WASHER, LOCK	96906 MS35338-004	EA		4	*	*	*	*		
0183					GROUP 05 - COOLING SYSTEM										
0184					0502-SHROUDS										
0185		0		5305-988-1723	SCREW, MACHINE: SHROUD MTG	96906 MS35026-279	EA		2	*	*	*	*	5	5
0186	X2	0		2930-384-8485	SHROUD ASSEMBLY: AIR	66289 SE53AS1	EA		1	*	*	*	*	5	1
0187		0		5310-582-5965	WASHER, LOCK: SHROUD MTG	96906 MS35338-044	EA		2	*	*	*	*	5	6
0188					GROUP 06 - ELECTRICAL SYSTEM										
0189					0605 - IGNITION COMPONENTS										
0190	P	0		2920-654-3499	MAGNETO, IGNITION: RADIO SHIELDED	21387 FMXDE1B7U	EA		1	*	*	2	2	7	4
0191	X2	0		2920-354-0750	CAM WICK AND HOLDER: ROTOR	21387 G2788	EA		1	*	*	*	*		
0192	P	0		5910-189-5518	CAPACITOR, FIXED, PAPER DIELECTRIC	21387 SXY2433	EA		1	*	2	3	5		
0193	P	0		5340-675-5753	CLIP, RETAINING: FULCRUM PIN	21387 T1498	EA		1	*	*	2	2		
0194	P	0		2920-294-4001	COIL, MAGNETO	82796 D2477A	EA		1	*	*	2	2		
0195	P	0		2920-319-5055	CONTACT SET, DISTRUBUTOR	21387 A2437A	EA		1	2	4	8	17		
0196	P	0		2920-510-1298	GASKET: END CAP	21387 K2498	EA		1	2	4	8	17		
0197	P	0		2920-517-0618	GEAR, HELICAL: IMPULSE COUPLING DRIVE	66289 GD87B	EA		1	*	*	*	*		
0198		0		5310-737-2632	NUT, CATELLATED, HEXAGON: IMPULSE COUPLING TO SHAFT RETAINING	21387 M2570	EA		1	*	*	*	*		
0199		0		5305-984-6189	SCREW, MACHINE: CAPACITOR MTG	96906 MS35206-241	EA		1	*	*	*	*		
0200		0		5305-012-1832	SCREW, MACHINE: CONTACT SET	02032 JHP13-402	EA		1	*	*	*	*		
0201		0		5305-013-1885	SCREW, MACHINE: CONTACT SET	12440 3103657	EA		1	*	*	*	*		
0202		0		5305-272-5306	SCREW, MACHINE: CONTACT SET	24617 1326969	EA		1	*	*	*	*		
0203	P	0		2920-354-0741	SPRING, SPIRAL, TORSION: COUPLING DRIVE	21387 D2565	EA		1	*	*	*	*		
0204		0		5310-637-3348	WASHER, FLAT: STATIONARY CONTACT SUPPORT SCREW	43999 2W1-11-12-20	EA		1	*	*	*	*		
0205		0		5310-366-7180	WASHER, FLAT: SUPPORT PLATE SCREW	21387 D2458	EA		1	*	*	*	*		
0206		0		5310-045-3299	WASHER, LOCK: CAPACITOR MTG	96906 MS35388-42	EA		1	*	*	*	*		

LINE NO.	(1) SOURCE, MAINT. AND RECOV.			(2) FEDERAL STOCK NUMBER	(3) DESCRIPTION	(4) MANUFACTURER'S CODE PART NUMBER	(5) UNIT OF ISSUE	(6) QTY INC		(7) 15 DAY ORG. MAINT. ALW.				(8) ILLUS- TRATION	
	(A) SOURCE	(B) MAINT.	(C) RECOV.					IN UNIT	INC PACK	(A) 1-5	(B) 6-20	(C) 21-50	(D) 51-100	(A) FIG. NO.	(B) ITEM OR SYM. NO
0207		0		5310-045-3299	WASHER, LOCK: CONTACT SET	96906 MS35388-42	EA		1	*	*	*	*		
0208		0		5310-013-1044	WASHER, LOCK: CONTACT SET	02032 JHP13-430	EA		1	*	*	*	*		
0209	X2	0		2920-366-7182	WIRE, LOCK: IMPULSE COUPLING NUT	21387 A5931A	EA		1	*	*	*	*		
0210	P	0		2920-620-0291	CABLE ASSEMBLY, SPECIAL PURPOSE, ELECTRICAL: SPARK PULG	66289 YD259	EA		1	*	*	*	2	7	3
0211	P	0		2920-517-9027	SLEEVE, IGNITION TERMINAL: SPARK PLUG CABLE	66289 YD109	EA		1	*	2	2	5		
0212	X1			2920-047-4530	GASKET:MAGNETO FLANGE (COMPONENT OF GASKET SET, STOCK NO. 2805-397-1748, SEE GROUP 0100)	66289 QD570A	EA		1					2	19
0213	P	0		2920-509-9612	SPARK PLUG: RADIO SHIELDED, 18 MM	66289 YD171	EA		1	4	8	16	34		
0214	P	0		5330-467-3553	GASKET: SPARK PLUG, 18 MM, SOLID COPPER	79150 2106A	EA		1	2	2	4	8		
0215		0		5306-019-3484	BOLT, MACHINE: MAGNETO MTG	24617 193484	EA		1	*	*	*	*	2	16
0216		0		5310-582-5615	NUT, PLAIN, HEXAGON: MAGNETO MTG	96906 MS35690-522	EA		2	*	*	*	*	2	18
0217		0		5307-405-9938	STUD, PLAIN: MAGNETO MTG	24617 272962	EA		1	*	*	*	*	2	15
0218		0		5310-013-8538	WASHER, LOCK: MAGNETO MTG	24617 138538	EA		2	*	*	*	*	2	17
0219					GROUP 22 - BODY, CHASSIS OR HULL AND ACCESSORY ITEMS										
0220					2202 - ACCESSORY ITEMS										
0221	X2	0		4940-672-4764	BOX ASSEMBLY: PRESSURE PUMP	05748 12189SA	EA		1	*	*	*	*		
0222	X2	0		5340-672-1926	BUMPER: RUBBER, PUMPING ASSEMBLY CARRYING HANDLE (U/O BARNES MODEL 15671CA PUMPING ASSEMBLY)	05748 15363	EA		2	*	*	*	*		
0223	X2	0		5340-672-1927	GRIP, HANDLE: PUMPING ASSEMBLY CARRYING HANDLE (U/O BARNES MODEL 15671CA PUMPING ASSEMBLY)	12505 B1B10-5-0	EA		2	*	*	*	*		
0224		0		5310-012-0614	NUT, PLAIN, HEXAGON	96906 MS35650-102	EA		2	*	*	*	*		
0225	X2	0		5975-577-8825	ROD: GROUND	05748 15675	EA		1	*	*	*	*		
0226		0		5305-559-9202	SCREW, CAP, HEXAGON HEAD: BOX MTG	96906 MS35297-3	EA		4	*	*	*	*		
0227		0		5305-993-1848	SCREW, MACHINE	96906 MS35207-265	EA		2	*	*	*	*		
0228		0		5310-582-5965	WASHER, LOCK: BOX MTG	96906 MS35338-044	EA		4	*	*	*	*		
0229	M	0		4940-672-4771	WIRE ASSEMBLY: W/FITTINGS, GROUND MANUFACTURE FROM:	05748 K676A	EA		1						
0229A	X2	0			CLAMP: WIRE TO ROD	05748 15877	EA		1						
0229B	X2	0			LUG: CLAMP TYPE, GROUND WIRE	05748 15878	EA		1						
0229C	P	0		6145-519-2833	WIRE, ELECTRICAL	05748 15876	FT								SEEGRP 9501

LINE NO.	(1) SOURCE, MAINT. AND RECOV.			(2) FEDERAL STOCK NUMBER	(3) DESCRIPTION	(4) MANUFACTURER'S CODE PART NUMBER		(5) UNIT OF ISSUE	(6) QTY INC IN UNIT		(7) 15 DAY ORG. MAINT. ALW.				(8) ILLUS-TRATION	
	(A) SOURCE	(B) MAINT.	(C) RECOV.			(A) (B) (C) (D)	(A) (B) (C) (D)		(A) (B) (C) (D)	(A) (B) (C) (D)	(A) FIG.	(B) ITEM OR SYM.				
0230					GROUP 55 - PUMPS											
0231					5500 - PUMP ASSEMBLY											
0232		0		5306-225-9081	BOLT, MAHCINE	96906 MS35297-036	EA		2		*	*	*	*		
0233		0		4730-735-4389	CROSS: PRESSURE PUMP OUTLET	01400 115-33	EA		1		*	*	*	*		
0234	P	0		4320-360-0601	GASKET SET: BODY TO INTERMEDIATE COUPLING C/O THE FOLLOWING ITEMS:	05748 8121SA	EA		1		*	*	2	2	7	13
0235		0		5310-012-0376	NUT, PLAIN, HEXAGON	96906 MS35690-505	EA		2		*	*	*	*		
0236	P	0	R	4320-360-0608	PUMP ASSEMBLY: W/O ENGINE	05748 164185A	EA		1		*	*	*	*		
0237		0		5310-012-0214	WASHER, LOCK	96906 MS35338-26	EA		2		*	*	*	*		
0240	P	0		4320-360-0599	GASKET: SUCTION CHECK VALVE	05748 8026	EA		1		*	2	2	3		
0241		0		4730-021-9307	PLUG, PIPE: DRAIN, SQ HEAD	24617 219307	EA		1		*	*	*	*	7	11
0242					5501 - SHAFT, ROTORS, IMPELLERS											
0243	P	0		4320-360-0598	IMPELLER	05748 8023	EA		1		*	*	2	2	7	6
0244	P	0		4320-360-0597	SEAL ASSEMBLY: INTERMEDIATE COUPLING	05748 8022	EA		1		*	*	*	2	7	14
0245	P	0		4320-360-0602	SHIM SET: IMPELLER	05748 8139SA	EA		1		*	*	*	2	7	5
0248					5505 - SUCTION AND/OR DISCHARGE ASSEMBLY											
0249	X2	0		4320-360-0587	FLANGE: SUCTION HOSE	05748 15669	EA		1		*	*	*	*	7	9
0250	X2	0		4320-360-0583	NIPPLE, PIPE: DISCHARGE TEE (NOT REQUIRED WHEN FSN 4730-735-4389 CROSS IS USED)	05748 3350	EA		1		*	*	*	*	7	7
0251		0		5310-012-0377	NUT, PLAIN, HEXAGON: FLANGE MTG	96906 MS35690-605	EA		3		*	*	*	*		
0252		0		5307-360-0580	STUD: FLANGE	05748 2418	EA		3		*	*	*	*	7	8
0253	P	0		4320-377-6981	SUCTION STUB ASSEMBLY: ALUMINUM, DRUM UNLOADER	05748 8215SA	EA		1		*	*	*	*		
0254	P	0		4320-360-0600	VALVE ASSEMBLY: CHECK, SUCTION	05748 8117SA	EA		1		*	*	*	2	7	10
0255	X2	0		4320-360-0596	CHAIN: W/S HOODS, STUB	81718 H6683M	EA		1		*	*	*	*	8	3
0256	X2	0		4320-360-0604	COUPLER: ELBOW, FEMALE, STUB	81718 633H11-2	EA		1		*	*	*	*	8	1
0257	X2	0		5340-816-4368	PLUG, PROTECTIVE, DUST: DUST, STUB	81718 249G8	EA		1		*	*	*	*	8	2
0258	X2	0		4320-360-0603	TUBE: STUB	81718 249G8	EA		1		*	*	*	*	8	4
0259		0		4730-360-0578	CAP: NOZZLE	81718 HB1461	EA		2		*	*	*	*	9	2
0260		0		4730-360-0572	CAP: W/CHAIN AND SPRING, SPOUT	81718 296C115-8	EA		2		*	*	*	*	9	3
0261	P	0		4930-360-0569	NOZZLE, FUEL AND OIL SERVICING: PRESSURE PUMP DISCHARGE HOSE	81718 CC21011-2	EA		2		*	*	*	2	9	1
0262	P	0		4930-904-1383	PARTS KIT, FUEL AND OIL SERVICING NOZZLE: DISCHARGE HOSE	81718 H4126	EA		2		*	*	*	2		
0263	P	0		4730-360-0571	C/O THE FOLLOWING ITEMS: SPOUT: NOZZLE	81718 29611-2X15-8	EA		2		*	*	*	2	9	4
0264	X1				DISC: LOWER	81718 H502M	EA		1							

LINE NO.	(1) SOURCE, MAINT. AND RECOV.			(2) FEDERAL STOCK NUMBER	(3) DESCRIPTION	(4) MANUFACTURER'S CODE PART NUMBER	(5) UNIT OF ISSUE	(6) QTY INC		(7) 15 DAY ORG. MAINT. ALW.				(8) ILLUS-TRATION		
	(A) SOURCE	(B) MAINT.	(C) RECOV.					IN	PACK	(A) 1-5	(B) 6-20	(C) 21-50	(D) 51-100	(A) FIG. NO.	(B) ITEM OR SYM. NO	
0270	X1				PACKING	81718 H714M	EA		1							
0271	X1				PACKING NUT	81718 H113RA	EA		1							
0272	X1				POPPER, UPPER	81718 C838M	EA		1							
0273	X1				POPPET, SUB-ASSEMBLY, MAIN	81718 H4682	EA		1							
0274					5510 - INLET AND OUTLET COMPONENTS											
0275	X2	0		4730-360-0592	COUPLING HALF, QUICK DISCONNECT: PRESSURE PUMP SUCTION HOSE, 1 1/2 IN.	96906 MS27021-9	EA		2	*	*	*	*			
0276	X2	0		4320-360-0594	CAP: FEMALE, DUST, PRESSURE PUMP DISCHARGE AND SUCTION	81718 634B11-2	EA		8	*	*	*	*			
0277	P	0		4320-360-0596	CHAIN: W/S HOOKS, PRESSURE PUMP SUCTION AND DISCHARGE DUST CAP	81718 H6683M	EA		8	*	*	*	*	2		
0278		0		4730-494-0871	CLAMP, HOSE: PRESSURE PUMP, DISCHARGE AND SUCTION HOSE	77414 16	EA		16	*	*	*	*			
0279	P	0		4940-360-0711	COUPLER: FEMALE, PRESSURE PUMP DISCHARGE TEE, MALE THREAD	81718 633B11-2	EA		1	*	*	*	*			
0280	X2	0		4730-360-0589	COUPLING HALF, QUICK DISCONNECT: PRESSURE PUMP SUCTION AND DISCHARGE HOSE	81718 633F11-2	EA		5	*	*	*	*			
0281	P	0		4320-360-0591	COUPLING HALF, QUICK DISCONNECT: W/SHANK, FEMALE, PRESSURE PUMP DISCHARGE AND SUCTION HOSE	81718 633C11-2	EA		6	*	*	*	*	2		
0282	P	0		4320-360-0595	GASKET: KAMLOCK TYPE, DISCHARGE AND SUCTION HOSE COUPLER	81718 H6430M	EA		14	*	2	2	3			
0283	P	0		4720-303-4984	HOSE ASSEMBLY: DISCHARGE	05748 15656SA	EA		2	*	*	*	*	2		
0283A	P	0		4720-555-8325	HOSE ASSEMBLY, RUBBER	05748 1567SA	EA		1	*	*	*	*	*		
0284	P	0		4320-360-0593	PLUG, PROTECTIVE, DUST: MALE, DUST PRESSURE PUMP DISCHARGE AND SUCTION HOSE COUPLER	81718 634A11-2	EA		7	*	*	2	2			
0285	X2	0			TEE, PIPE: SIDE OUTLET, PRESSURE PUMP DISCHARGE (REPLACED BY FSN 4730-735-4389 CROSS)	63686 7119-1-1-2	EA		1	*	*	*	*			
0286					5511 - COUPLINGS											
0287	X2	0		4320-360-0586	COUPLING: INTERMEDIATE, PUMP TO ENGINE	05748 5364	EA		1	*	*	*	*	7	15	
0288		0		5310-012-0377	NUT, PLAIN, HEXAGON	96906 MS35690-605	EA		10	*	*	*	*			
0289		0		5305-269-3214	SCREW, CAP, HEXAGON HEAD	96906 MS90725-64	EA		4	*	*	*	*			
0290		0		5307-360-0579	STUD: INTERMEDIATE COUPLING	05748 2417	EA		6	*	*	2417	*	7	12	
0291		0		5310-012-0382	WASHER, LOCK	24617 120382	EA		4	*	*	*	*			
0301					GROUP 95 - GENERAL USE STANDARDIZED PARTS											
0302					9501 - HARDWARE SUPPLIES AND BULK MATERIAL, COMMON											
0304	P	0		6145-519-2833	WIRE, ELECTRICAL	05748 15876	FT			*	2	2	4			

LINE NO.	(1) SOURCE, MAINT. AND RECOV.			(2) FEDERAL STOCK NUMBER	(3) DESCRIPTION	(4) MANUFACTURER'S CODE	(5) PART NUMBER	(6) UNIT OF ISSUE	(5) QTY INC		(7) 15 DAY ORG. MAINT. ALW.				(8) ILLUS-TRATION	
	(A) SOURCE	(B) MAINT.	(C) RECOV.						IN	PACK	(A) 1-5	(B) 6-20	(C) 21-50	(D) 51-100	(A) FIG. NO.	(B) ITEM OR SYM. NO
0305					SECTION - SPECIAL TOOLS, TEST AND SUPPORT EQUIPMENT FOR ORGANIZATIONAL MAINTENANCE											
0307					GROUP 26 - TOOLS AND TEST EQUIPMENT											
0308					2604 - SPECIAL TOOLS											
0309					NOTE: IF THESE TOOLS ARE NOT COMPONENTS OF AUTHORIZED TO & E TOOL SETS, ONE EACH IS AUTHORIZED PER USING UNIT.											
0310	P	0		5120-359-6587	CLAMPING TOOL, STRAP ASSEMBLY C/O THE FOLLOWING ITEMS:	77414	P38	EA		1	*	*	*	*		
0311	X1				FRAME	77414	D285A	EA		1						
0312	X1				PUNCH AND WINDER	77414	D289A	EA		1						
0313	X1				WINDER	77414	D290F	EA		1						
0314	X1				WRENCH: RACHET	77414	D298A	EA		1						



LINE NO.	(1) SOURCE, MAINT. AND RECOV.			(2) FEDERAL STOCK NUMBER	(3) DESCRIPTION	(4) MANUFACTURER'S CODE PART NUMBER		(5) UNIT OF ISSUE	(6) QTY INC IN UNIT		(7) 30-DAY DS/GS MAINT. ALW.			(8) 1-YR. ALW. PER 100 EQUIP. CTNGCY. PLANNING		(9) DEPOT MAINT. ALW. PER. 100 EQUIP.	(10) ILLUSTRATION (A) FIG. NO. (B) ITEM OR SYM. NO.	
	(A)	(B)	(C)			1-20	(B)		(C)	1-20	21-50	51-100	(A)	(B)				
0001					SECTION V - REPAIR PARTS FOR DS, GS, AND DEPOT MAINTENANCE													
0002					GROUP 01 - ENGINE													
0003					0100 - ENGINE ASSEMBLY													
0004	P	0		2805-397-1748	GASKET SET: ENGINE OVERHAUL	66289 Q2	EA	1		2	2	2	25					
0005	X1			5330-239-1471	GASKET: CARBURETOR FLANGE	66289 QC53	EA	1		SEE GRP 0301								
0006	X1			2805-351-6835	GASKET: CYLINDER HEAD	74340 QD604A	EA	1		SEEGRP 0101								
0007	X1			2805-376-0398	GASKET: ENGINE BASE	66289 QD569A	EA	1		SEEGRP 0101								
0008	X1			5330-285-5061	GASKET: GOVERNOR YOKE SHAFT BRACKET	66289 QD571	EA	1		SEEGRP 0303								
0009	X1			2920-047-4530	GASKET: MAGNETO FLANGE	66289 QD570A	EA	1		SEEGRP 0605								
0010	X1			2805-244-8184	GASKET: MAIN BEARING PLATE, FLYWHEEL END	66289 QD574	EA	1		SEE GRP 0102								
0011	X1			5330-266-2701	GASKET:MAIN BEARING PLATE,TAKE-OFF END .006 THK	66289 QD573	EA	5		SEE GRP 0102								
0012	X1			5330-298-5170	GASKET:MAIN BEARING PLATE,TAKE-OFF END, .003 THK	66289 QD573A	EA	1		SEE GRP 0102								
0013	X1			2805-268-3448	GASKET: VALVE CHAMBER INSPECTION PLATE	66289 QD572	EA	1		SEE GRP 0105								
0014		0		5310-021-0377	NUT, PLAIN, HEXAGON: POWER UNIT MTG	96906 MS35690-605	EA	4		*	*	*	*					
0015	P	0	R	2805-672-1918	POWER UNIT, GASOLINE: READY TO RUN SUPERSEDES FSN 2805-358-2473 ENGINE ASSEMBLY	66289 BKND162685	EA	1		*	*	*	*					
0016		0		5305-269-3218	SCREW, CAP, HEXAGON HEAD: POWER UNIT MTG	24617 180134	EA	4		*	*	*	*					
0017		0		5310-012-0382	WASHER, LOCK: POWER UNIT MTG		EA	4		*	*	*	*					
0018		0		5310-013-8489	(81349) FPN.84, CLASS A STYLE A2 WASHER, LOCK: POWER UNIT MTG	81349 MILB6986TYPEA	EA	8		*	*	*	*					
0019					0101 - CRANKCASE, BLOCK, CYLINDER HEAD													
0020		0		5306-018-0081	BOLT, MACHINE: HEAD MTG	96906 MS35297-036	EA	5		*	*	*	*			1		
0021		0		5306-018-0087	BOLT, MACHINE: HEAD MTG	96906 MS35297-40	EA	3		*	*	*	*			1		2
0022	X2	0		2805-033-6140	BREATHER: CRANKCASE	66289 L0-31A	EA	1		*	*	*	*					
0023	X1			2805-351-6835	GASKET: CYLINDER HEAD (COMPONENT OF GASKET SET, STOCK NO. 2805-397-1748, SEE GROUP 0100)	74340 QD604A	EA	1								1		6
0024	X1			2805-376-0398	GASKET: ENGINE BASE (COMPONENT OF GASKET SET, STOCK NO. 2805-397-1748, SEE GROUP 0100)	66289 QD569A	EA	1								1		10
0025	X2	0		2805-672-1922	HEAD: CYLINDER	66289 AB99P2	EA	1		*	*	*	*			1		5
0026	X2	H		5340-050-1591	PLUG, EXPANSION: CAMSHAFT SUPPORT PIN		EA	2		*	*	*	*			1		8
0027		0		4730-042-6318	HOLE PLUG, PIPE: CRANKCASE TIMING INSPECTION HOLE	96906 MS35648-4	EA	2		*	*	*	*			1		8
						24617 103885	EA	1		*	*	*	*			1		9

LINE NO.	(1) SOURCE, MAINT. AND RECOV.			(2) FEDERAL STOCK NUMBER	(3) DESCRIPTION	(4) MANUFACTURER'S CODE PART NUMBER		(5) UNIT OF ISSUE	(6) QTY INC IN UNIT PACK		(7) 30-DAY DS/GS MAINT. ALW.			(8) 1-YR. ALW. PER 100 EQUIP. CTNGCY. PLANNING		(9) DEPOT MAINT. ALW. PER. 100 EQUIP.	(10) ILLUSTRATION (A) (B)	
	(A) SOURCE	(B) MAINT.	(C) RECOV.			(A) 1-20	(B) 21-50		(C) 51-100	(A) 100	(B) 200	(A) FIG. NO.	(B) ITEM OR SYM. NO.					
0028	X2	0		4730-021-9199	PLUG, PIPE: CYLINDER OIL FILLER, SQ HEAD, 1/2 IN. (81348) WWP471, TYPE 2, STYLE A			EA		1	*	*	*	*	*		1	7
0029		0		4730-622-1607	PLUG, PIPE, MAGNETIC: ENGINE BASE OIL DRAIN	66289 XK2A		EA		1	*	*	*	*	*		1	11
0030	F			5305-068-0502	SCREW, CAP, HEXAGON HEAD: ENGINE BASE MTG	96906 MS90725-6		EA		10	*	*	*	*	*		1	12
0031	F			5310-190-0743	WASHER, FLAT: ENGINE BASE MTG SCREW	66289 PH30A		EA		10	*	*	*	*	*		1	13
0032	0			5310-616-3023	WASHER, FLAT: HEAD MTG	96906 MS15795-212		EA		7	*	*	*	*	*		1	4
0033	0			5310-012-0214	WASHER, LOCK: HEAD MTG	96906 MS35338-26		EA		1	*	*	*	*	*		1	3
0034					0102 - CRANKSHAFT													
0035	P	H		2805-358-2303	CRANKSHAFT ASSEMBLY: W/BEARINGS, GEAR AND KEY	66289 CA51-88S1		EA		1	*	*	2	8		4	2	22
0036	P	H		3110-100-3158	CONE AND ROLLERS, TAPERED ROLLER BEARING: MAIN	60038 15118		EA		2	2	2	3	32		30	2	7
0037	P	H		3110-100-0522	CUP, TAPERED ROLLER BEARING: MAIN	60038 15250		EA		2	2	2	3	32		30	2	8
0038	P	H		2805-249-9903	GEAR, HELICAL	66289 GA34A		EA		1	*	2	2	20		12	2	6
0039	H			5315-616-5514	KEY, WOODRUFF: NO. 3	96906 MS35756-6		EA		1	*	*	*	*		*	2	4
0040	F			5306-616-1287	BOLT, MACHINE: BEARING PLATE MTG	96906 MS35297-32		EA		4	*	*	*	*		*	2	24
0041	P	H		5330-141-4906	GASKET: CORK, MAIN BEARING	66289 PH256		EA		2	3	7	13	160		200	2	9
0042	X1			2805-244-8184	GASKET: BEARING PLATE, FLYWHEEL END (COMPONENT OF GASKET SET, STOCK NO. 2805-397-1748, SEE GROUP 0100)	66289 QD574		EA		1							2	10
0043	X1			5330-266-2701	GASKET: MAIN BEARING PLATE, TAKE-OFF END (COMPONENT OF GASKET SET, STOCK NO. 2805-397-1748, SEE GROUP 0100)	66289 QD573		EA		5							2	26
0044	X1			5330-298-5170	GASKET: MAIN BEARING PLATE, TAKE-OFF END, .003 THK (COMPONENT OF GASKET SET, STOCK NO. 2805-397-1748, SEE GROUP 0100)	66289 QD573A		EA		1							2	27
0045	X2	F		2805-358-3077	PLATE ASSEMBLY: BEARING, TAKE-OFF END	66289 BG170S1		EA		1	*	*	*	*		*	2	25
0046	P	F		2805-353-5849	PLATE ASSEMBLY: W/OIL SEAL, BEARING, FLYWHEEL END	66289 BG171S1		EA		1	2	3	7	80		100	2	11
0047	P	F		5330-298-5744	RETAINER, PACKING: MAIN BEARING OIL SEAL	66289 PH254		EA		2	3	7	13	160		200		
0048	F			5305-068-0500	SCREW, CAP, HEXAGON HEAD: PLATE ASSEMBLY MTG	96906 MS90725-3		EA		4	*	*	*	*		*	2	12
0049	F			5310-675-5755	WASHER, FLAT: BEARING PLATE, TAKE-OFF END	66289 PH412		EA		4	*	*	*	*		*	2	23
0050	F			5310-582-5965	WASHER, LOCK: PLATE ASSEMBLY MTG	96906 MS35338-044		EA		4	*	*	*	*		*	2	13
0051					0103-FLYWHEEL ASSEMBLY													
0052	X2	F		2805-376-0395	FLYWHEEL ENGINE	66289 NC137		EA		1	*	*	*	*		*	5	7
0053	F			5315-012-4552	KEY, WOODRUFF: NO. 13			EA		1	*	*	*	*		*	2	5

LINE NO.	(1) SOURCE, MAINT. AND RECOV. CODE (A) (B) (C) SOURCE MAINT. RECOV.			(2) FEDERAL STOCK NUMBER	(3) DESCRIPTION	MANUFACTURER'S CODE PART NUMBER	(4) UNIT OF ISSUE	(5) QTY INC IN UNIT		(6) 30-DAY DS/GS MAINT. ALW. (A) (B) (C)			(7) 1-YR. ALW. PER 100 EQUIP. CTNGCY. PLANNING	(8) DEPOT MAINT. ALW. PER. 100 EQUIP.	(9) ILLUSTRATION (A) (B) FIG. ITEM OR NO. SYM. NO.	
	QTY INC IN UNIT	QTY INC IN UNIT	1-20					21-50	51-100	(A)	(B)	(C)				
0054					0104 - PISTONS, CONNECTING RODS											
0055 P	H			2805-033-6135	PIN, PISTON	66289 DE68S5	EA		1	*	2	2	20	100	2	28
0056 P	H			2805-696-0040	PISTON, INTERNAL COMBUSTION ENGINE: W/PIN, RETAINERS AND RINGS, STANDARD	66289 DP4	EA		1	*	2	2	20	10	2	29
0057 P	H			5340-291-8235	RING, RETAINING: PIN	66289 PK69	EA		2	3	7	13	160	20	2	2
0058 P	H			2805-555-2119	RING SET, PISTON: STANDARD	66289 DR30	EA		1	2	4	8	100	10	2	1
0059	H			5306-550-1642	BOLT, MACHINE: CAP	96906 MS35301-36	EA		2	*	*	*	*	*	2	21
0060 P	H			2805-672-9509	CONNECTING ROD ASSEMBLY	66289 DA70BS1	EA		1	*	*	2	8	5	2	3
0061 X2	H			5310-290-5759	WASHER, KEY: BOLT	66289 PE82	EA		2	*	*	*	*	*	2	20
0062					0105 VALVES, CAMSHAFTS AND TIMING SYSTEM											
0063 P	H			2805-428-2094	CAMSHAFT ASSEMBLY: W/GEAR AND SUPPORT PIN	66289 EA101DS1	EA		1	*	*	2	8	3	3	11
0064 X1				2805-268-3448	GASKET: VALVE CHAMBER INSPECTION PLATE (COMPONENT OF GASKET SET, STOCK NO. 2805-397-1748, SEE GROUP 0100)	66289 QD572	EA		1						1	28
0065	H			5315-616-5514	KEY, WOODRUFF: CAMSHAFT GEAR	96906 MS35756-6	EA		1	*	*	*	*	*		
0066 P	H			2805-630-1110	LIFTER, VALVE	66289 FA42A	EA		2	*	*	2	8	6	3	10
0067 P	F			2805-277-2918	LOCK: VALVE SPRING SEAT (PAIR)	66289 AH9	EA		2	2	2	3	40	10	3	9
0068	H			5315-221-0480	PIN, STRAIGHT, HEADLESS: SUPPORT	66289 PA264	EA		1	*	*	*	*	*	3	17
0069 X2	0			2805-376-0416	PLATE: VALVE CHAMBER INSPECTION	66289 SA61	EA		1	*	*	*	*	*	1	26
0070 X2	0			2805-376-0385	PLUG, BREATHER: VALVE CHAMBER	66289 PF102	EA		1	*	*	*	*	*		
0071 P	F			2805-301-2940	ROTATOR, ENGINE POPPET	66289 AG31	EA		1	2	3	5	60	30		
0072	0			5305-071-2239	SCREW, CAP, HEXAGON HEAD: INSPECTION PLATE MTG	96906 MS90725-12	EA		1	*	*	*	*	*	1	15
0073 P	F			2805-143-6657	SEAT, COMPRESSION: INTAKE VALVE SPRING	66289 AG26	EA		1	*	*	2	8	5	3	8
0074 P	H			2805-776-8151	SEAT, VALVE: EXHAUST	66289 HG201D	EA		1	*	*	2	8	5	2	14
0075 P	F			2805-505-5191	SPRING, HELICAL, COMPRESSION: EXHAUST VALVE	66289 AF49A	EA		1	2	3	5	60	30	3	4
0076 P	F			5340-250-0098	SPRING, HELICAL, COMPRESSION: INTAKE VALVE	66289 AF43	EA		1	2	3	5	60	30	3	7
0077	0			5310-285-8538	WASHER, FLAT: INSPECTION PLATE MTG	66289 PH30	EA		1	*	*	*	*	*	1	14
0078 P	F			2805-270-3429	VALVE, POPPET, ENGINE INTAKE	66289 AE74C	EA		1	2	2	3	40	20	3	6
0079 P	F			2805-448-1050	VALVE, POPPET, ENGINE: STELLITE, EXHAUST	66289 AE74D	EA		1	2	2	3	40	20	3	5
0080					0106 - ENGINE LUBRICATION SYSTEM											
0081 X2	H			2805-376-0382	BODY: OIL PUMP	66289 KA59B1S1	EA		1	*	*	*	*	*	4	6
0082	H			2805-147-3739	CAP, PUSH ROD: OIL PUMP PLUNGER	66289 KF19A	EA		1	*	*	*	*	*	4	2
0083 X2	H			2805-447-9294	COVER: OIL PUMP BODY	66289 SA80	EA		1	*	*	*	*	*		
0084 P	H			2805-376-0417	PLUNGER ASSEMBLY: OIL PUMP	66289 KF14S1	EA		1	*	2	2	20	25	4	3

LINE NO.	(1) SOURCE, MAINT. AND RECOV. CODE (A) (B) (C) SOURCE MAINT. RECOV.			(2) FEDERAL STOCK NUMBER	(3) DESCRIPTION	(4) MANUFACTURER'S CODE PART NUMBER	(5) UNIT OF ISSUE	(6) QTY INC IN UNIT PACK	(7) 30-DAY DS/GS MAINT. ALW. (A) (B) (C) 1-20 21-50 51-100			(8) 1-YR. ALW. PER 100 EQUIP. CTNGCY. PLANNING	(9) DEPOT MAINT. ALW. PER. 100 EQUIP.	(10) ILLUSTRATION (A) (B) FIG. ITEM OR NO. SYM. NO.		
0085	P	H		2805-396-0853	RETAINER, OIL PUMP: BALL	66289 PK50	EA	1	*	2	2	20		25	4	9
0086	P	H		2805-376-0419	ROD: PUSH, OIL PUMP PLUNGER	66289 KF22	EA	1	*	2	2	20		25	4	1
0087		H		5305-225-3839	SCREW, CAP, HEXAGON HEAD: PUMP BODY MTG	81366 180022	EA	2	*	*	*	*		*	4	8
0088		H		5305-044-3760	SCREW, TAPPING, THREAD FORMING	00000 443760	EA	2	*	*	*	*		*		
0089	P	H		5340-147-3745	SPRING, HELICAL, COMPRESSION: OIL PUMP PLUNGER	66289 PM58	EA	1	*	2	2	20		20	4	4
0090	P	H		2940-888-0990	STRAINER, OIL PUMP	66289 RD107	EA	1	*	2	2	15		5	4	5
0091		H		5310-582-5965	WASHER, LOCK: PUMP BODY MTG	96906 MS35338-044	EA	2	*	*	*	*		*	4	7
0092					0107 - ENGINE STARTING SYSTEM											
0093	X2	0		2990-422-6161	PULLEY, ENGINE STARTER ROPE	66289 UC103A	EA	1	*	*	*	*		*	5	2
0094	P	0		2990-142-0080	STARTER ROPE, ENGINE	66289 UZ18A	EA	1	*	*	*	*		*	5	4
0095	X2	0		5310-013-8502	WASHER, LOCK: PULLEY MTG	96906 MS35335-25	EA	1	*	*	*	*		*	5	3
0096					GROUP 03 - FUEL SYSTEM											
0097					0301 - CARBURETOR											
0098	P	0		2910-255-2308	CARBURETOR, FLOAT	96152 VH53	EA	1	3	5	10	120		15	1	24
0099	P	F		2910-049-3711	GASKET ASSORTMENT											
					C/O THE FOLLOWING ITEMS:	96152 16-638	EA	1	3	5	10	120		100		
0100	X1			5330-247-6680	GASKET:BOWL	96152 16A83	EA	1								
0101	X1			5330-247-6879	GASKET: FLOAT BOWL NUT	96152 16-14	EA	1								
0102	X1				GASKET: MAIN DISCHARGE NOZZLE	96152 16A95	EA	1								
0103	X1			5330-291-7918	WASHER: FLOAT VALVE NEEDLE SEAT	96152 16-4	EA	1								
0104		0		5310-012-0367	NUT, PLAIN, HEXAGON: CARBURETOR MTG	96906 MS35690-425	EA	2	*	*	*	*		*	1	25
0105	P	0		5330-238-7951	PACKING: METERING NEEDLE	96152 44-51	EA	1	*	*	*	4		8		
0106		0		5307-286-0334	STUD, PLAIN: CARBURETOR MTG	66289 PC368	EA	2	*	*	*	*		*	1	29
0107	P	0		2910-364-4996	VALVE ASSEMBLY: NEEDLE AND SEAT, FLOAT	96152 233-536	EA	1	*	*	*	4		8		
0108	X1			5330-239-1471	GASKET: CARBURETOR FLANGE (COMPONENT OF GASKET SET, STOCK NO. 2805-348-6824, SEE GROUP 0100)	66289 QC53	EA	1							1	27
0109					0304 - AIR CLEANER											
0110	X2	0		2940-675-5751	BRACKET ASSEMBLY: CARBURETOR AIR CLEANER	66289 B1264BS1	EA	1	*	*	*	*		*	1	21
0111	P	0		2940-021-0587	ELEMENT AIR: W/O BRACKET, CARBURETOR	80749 76B1	EA	1	*	2	2	12		5	1	19
0112	P	0		2910-447-9260	GASKET: CARBURETOR AIR CLEANER BRACKET	66289 QD647	EA	1	2	2	3	40		100		
0113		0		5305-068-0502	SCREW, CAP, HEXAGON HEAD: STRAP MTG	81336 180020	EA	1	*	*	*	*		*	1	16
0114		0		5305-988-1727	SCREW, MACHINE: BRACKET MTG	96906 MS35206-283	EA	1	*	*	*	*		*	1	22
0115		0		5305-011-5137	SCREW, TAPPING, THREAD FORMING: ELEMENT TO BRACKET MTG	81336 115137	EA	3	*	*	*	*		*	1	20
0116	X2	0		2940-215-7226	STRAP: CARBURETOR AIR CLEANER BRACKET	66289 PG287	EA	1	*	*	*	*		*	1	18
0117		0		5310-809-4058	SUPPORT WASHER, FLAT: STRAP MTG	96906 MS15795-210	EA	1	*	*	*	*		*	1	23

LINE NO.	(1) SOURCE, MAINT. AND RECOV. CODE (A) (B) (C) SOURCE MAINT. RECOV.			(2) FEDERAL STOCK NUMBER	(3) DESCRIPTION	(4) MANUFACTURER'S CODE PART NUMBER	(5) UNIT OF ISSUE	(6) QTY INC IN UNIT	(7) 30-DAY DS/GS MAINT. ALW. (A) (B) (C) 1-20 21-50 51-100			(8) 1-YR. ALW. PER 100 EQUIP. CTNGCY. PLANNING	(9) DEPOT MAINT. ALW. PER. 100 EQUIP.	(10) ILLUSTRATION (A) (B) FIG. ITEM OR NO. SYM. NO.		
0118		0		5310-582-5965	WASHER, LOCK: STRAP MTG	96906 MS35338-044	EA		1	*	*	*	*	*	1	17
0119					0306 - TANKS, LINES, FITTINGS											
0120	X2	0		2910-464-3530	BRACKET: FUEL TANK	66289 BK71	EA		1	*	*	*	*	*		
0121	P	0		2910-672-1916	CAP, FUEL TANK	66289 RC104	EA		1	2	2	3	40	5	7	2
0122	P	0		4730-231-5632	ELBOW, PIPE TO TUBE, BRASS, CARBURETOR											
					FUEL	24617 118753	EA		2	*	*	2	8	5		
0123	P	0		5330-675-5752	GASKET: CAP	66289 QD694	EA		1	2	2	3	40	5		
0124	0			5310-176-8139	NUT, PLAIN, HEXAGON	19315 205-01-17	EA		2	*	*	*	*	*		
0125	F			4730-189-2729	NUT, TUBE COUPLING: FUEL FILTER TO CARBURETOR TUBE	10001 346503PC1	EA		2					*		
0126	0			5305-267-3209	SCREW, CAP, HEXAGON HEAD	96906 MS90725-28	EA		2	*	*	*	*	*		
0127	0			5305-988-9265	SCREW, MACHINE	96906 MS35206-286	EA		2	*	*	*	*	*		
0128	X2	0		2910-672-1914	STRAP: FUEL TANK	66289 PG733	EA		2	*	*	*	*	*		
0129	X2	0		2910-672-1915	TANK ASSEMBLY: W/CAP, FUEL	66289 WE14G	EA		1	*	*	*	*	*	7	1
0130	0			5310-012-0382	WASHER, LOCK	24617 120382	EA		2	*	*	*	*	*		
0131				5310-582-5965	WASHER, LOCK	96906 MS35338-044	EA		2	*	*	*	*	*		
0132	M	F			TUBE ASSEMBLY: FUEL FILTER TO CARBURETOR MANUFACTURE FROM:	66289 RP902	EA		1					*		
0132A	P	F		4710-277-5525	TUBING, COPPER (15 IN. REQUIRED)	09348 25-214554	FT			SEE	GRP	9501				
0133					0308 - ENGINE SPEED GOVERNOR AND CONTROLS											
0134	P	H		2990-661-8942	BEARING, SLEEVE: THRUST, GOVERNOR	66289 TC323	EA		1	*	*	*	2	10	3	15
0135	9			5306-356-0965	BOLT, HOOK: GOVERNOR CONTROL	66289 VE304	EA		1	*	*	*	*	*	3	19
0136	X2	H		2990-376-0386	BRACKET: GOVERNOR SHAFT SUPPORT	66289 TC325	EA		1	*	*	*	*	*	3	3
0137	X2	0		2990-383-9339	CONTROL ASSEMBLY: SPEED	66289 VE363A	EA		1	*	*	*	*	*	6	13
0138	X2	H		2990-376-0394	FLYWEIGHT: GOVERNOR	66289 TC322	EA		2	*	*	*	*	*	3	14
0139	X1			5330-285-5061	GASKET: GOVERNOR YOKE SHAFT BRACKET (COMPONENT OF GASKET SET, STOCK NO. 2805-368-6824, SEE GROUP 0100)	66289 QD571	EA		1					*	3	18
0140	X2	0		2990-301-6374	LEVER: GOVERNOR CONTROL	66289 TC332	EA		1	*	*	*	*	*	3	21
0141				5310-012-0367	NUT, PLAIN, HEXAGON	96906 MS35690-425	EA		1	*	*	*	*	*	3	2
0142	0			5315-828-8190	PIN, COTTER: GOVERNOR CONTROL	96906 MS24665-69	EA		1	*	*	*	*	*	3	20
0143	H			5315-663-1215	PIN, SHOULDER, HEADLESS: FLYWEIGHT	66289 TC328D	EA		1	*	*	*	*	*	3	13
0144	H			5315-687-3787	PIN, SPRING: FLYWEIGHT	96906 MS9048-171	EA		2	*	*	*	*	*	3	12
0145	H			5305-068-0500	SCREW, CAP, HEXAGON HEAD: BRACKET MTG	96906 MS90725-3	EA		2	*	*	*	*	*	3	1
0146	X2	H		2910-215-7236	SPACER: GOVERNOR	66289 TC321	EA		1	*	*	*	*	*	3	16
0147	P	O		2990-224-8188	SPRING, HELICAL, EXTENSION: GOVERNOR	66289 PM74	EA		1	*	2	2	20	8	3	22
0148	P	H		2990-511-7629	YOKE, GOVERNOR	66289 TC324C	EA		1	*	*	*	5	5	3	23
0149	X2	0		2990-536-2962	BLOCK: SPRING ADJUSTING SCREW	66289 TC301-3	EA		1	*	*	*	*	*	6	2
0150	0			5310-833-2080	NUT, PLAIN, HEXAGON: BLOCK MTG	96906 MS35650-101	EA		2	*	*	*	*	*	6	1
0151	0			5315-252-5989	PIN, COTTER: SPEED CONTROL	81348 PFP386TYPEB	EA		1	*	*	*	*	*	6	4

LINE NO.	(1) SOURCE, MAINT. AND RECOV. CODE			(2) FEDERAL STOCK NUMBER	(3) DESCRIPTION	(4) MANUFACTURER'S CODE	(5) PART NUMBER	(6) UNIT OF ISSUE	(7) QTY IN IN	(8) INC PACK	30-DAY DS/GS MAINT. ALW.			(9) 1-YR. ALW. PER 100 EQUIP. CTNGCY. PLANNING	(10) DEPOT MAINT. ALW. PER. 100 EQUIP.	(11) ILLUS-TRATION (A) FIG. NO.
	(A)	(B)	(C)								(A)	(B)	(C)			
	SOURCE	MAINT.	RECOV.								1-20	21-50	51-100			
0152		0		5315-265-9197	PIN, STRAIGHT, HEADLESS: LEVER	66289	PC393-2	EA	1	*	*	*	*	*	6	7
0153		0		5315-383-9335	PIN, STRAIGHT, THREADED: SPRING	66289	P1121	EA	1	*	*	*	*	*	6	3
0154	P	0		5340-256-7147	SPRING, HELICAL, COMPRESSION: LEVER SUPPORT STUD	66289	PM117	EA	1	*	2	2	20	8	6	6
0155		0		5310-809-4058	WASHER, FLAT: SPEED CONTROL	96906	MS15795-210	EA	1	*	*	*	*	*	6	5
0156		0		5310-082-1404	WASHER, LOCK: BLOCK TO CONTROL MTG	96906	MS27183-6	EA	1	*	*	*	*	*	6	14
0157		0		5310-012-0622	NUT, PLAIN, HEXAGON: SPEED CONTROL	81366	120585	EA	1	*	*	*	*	*	6	11
0158		0		5305-012-0585	SCREW, MACHINE: SPEED CONTROL	81366	132764	EA	1	*	*	*	*	*	6	8
0159		0		5305-013-2764	SCREW, MACHINE: SPEED CONTROL	81366	132764	EA	1	*	*	*	*	*	6	12
0160		0		5310-193-7407	WASHER, FLAT: LEAD, BRACKET SCREW	66289	PH221	EA	2	*	*	*	*	*	6	10
0161		0		5310-013-8604	WASHER, LOCK: SPEED CONTROL	08315	8630-29-24	EA	1	*	*	*	*	*	6	9
0162					0309-FUEL FILTER											
0163	P	0		4730-230-1996	NIPPLE, PIPE: BRASS, FUEL STRAINER	24617	142868	EA	1	*	*	2	8	3		
0164	P	0		4730-639-9638	STRAINER, SEDIMENT: FUEL	78480	0W480T	EA	1	*	*	2	8	3	7	16
0165	C2	0		2910-358-4316	BALL	78480	07766	EA	1	*	*	*	*	*		
0166	P	0		2910-358-4317	BOWL, SEDIMENT: GLASS	78480	07759	EA	1	3	5	10	120	10		
0167	P	0		2910-282-7557	GASKET: BOWL	78480	08227	EA	1	16	34	67	800	100		
0168	P	0		2910-358-5327	STRAINER ELEMENT, SEDIMENT	78480	07762	EA	1	*	*	2	8	5		
0169	P	0		5330-145-2017	WASHER, NONMETALLIC: SHUT-OFF VALVE	78480	0705	EA	1	16	34	67	800	100		
0170					GROUP 04 - EXHAUST SYSTEM											
0171					0401 - MUFFLER AND PIPES											
0172	P	0		4940-672-4768	ADAPTER: MALE, ENGINE EXHAUST NIPPLE, FEMALE THREAD	81718	633A1	EA	1	*	*	2	8	5		
0173	P	0		4730-193-6992	BEND, PIPE, RETURN: ENGINE EXHAUST	00000	179504	EA	1	*	*	2	8	5		
0174	P	0		5306-672-1923	MUFFLER	05748	15664	EA	1	*	*	*	*	*		
0175	P	0		4940-672-4769	BOLT, U: MUFFLER AND EXHAUST ASSEMBLY MTG BRACKET	05748	15664	EA	1	*	*	*	*	*		
0176	P	0		4940-672-4769	COUPLER PIPE: FEMALE, ENGINE EXHAUST	81718	633D1	EA	1	*	*	2	8	5		
0177	P	0		4730-246-1219	MUFFLER FEMALE THREAD	24617	108687	EA	1	*	*	*	*	*		
0178	P	0		4940-672-4767	ELBOW, PIPE: STREET, ENGINE EXHAUST	05748	16418SA	EA	1	4	8	17	200	100		
0179	P	0		2990-389-6412	GASKET SET: ENGINE EXHAUST MUFFLER	76700	T1802D	EA	1	2	2	3	40	25		
0180		0		4730-021-9678	COUPLER	24617	219678	EA	1	*	*	*	*	*		
0181		0		5310-176-8139	MUFFLER, EXHAUST: ENGINE	19315	20501-17	EA	4	*	*	*	*	*		
0182		0		5305-225-3839	NIPPLE, PIPE: ENGINE EXHAUST	96906	MS90725-8	EA	4	*	*	*	*	*		
		0		5310-582-5965	NUT, PLAIN, HEXAGON	96906	MS35338-004	EA	4	*	*	*	*	*		
		0			SCREW, CAP, HEXAGON HEAD: EXHAUST NIPPLE BRACKET											
		0			WASHER, LOCK											

LINE NO.	(1) SOURCE, MAINT. AND RECOV. CODE (A) (B) (C) SOURCE MAINT. RECOV.			(2) FEDERAL STOCK NUMBER	(3) DESCRIPTION	(4) MANUFACTURER'S CODE PART NUMBER		(5) UNIT OF ISSUE	(6) QTY INC IN UNIT	(7) 30-DAY DS/GS MAINT. ALW. (A) (B) (C)	(8) 1-YR. ALW. PER 100 EQUIP. CTNGCY. PLANNING	(9) DEPOT MAINT. ALW. PER. 100 EQUIP.	(10) ILLUSTRATION (A) FIG. NO. (B) ITEM OR SYM. NO.		
	0183					GROUP 05 - COOLING SYSTEM									
0184					0502 - SHROUDS										
0185		0		5305-988-1723	SCREW, MACHINE: SHROUD MTG	96906 MS35026-279	EA	2	*	*	*	*	5		5
0186	X2	0		2930-384-8485	SHROUD ASSEMBLY: AIR	66289 SE53AS1	EA	1	*	*	*	*	5		1
0187		0		5310-582-5965	WASHER, LOCK: SHROUD MTG	96906 MS35338-044	EA	2	*	*	*	*	5		6
0188					GROUP 06 - ELECTRICAL SYSTEM										
0189					0605 - IGNITION COMPONENTS										
0190	P	0		2920-654-3499	MAGNETO, IGNITION: RADIO SHIELDED	21387 FMXDE1B7U	EA	1	2	2	3	40	2		4
0191	X2	0		2920-354-0750	CAM WICK AND HOLDER: ROTOR	21387 G2788	EA	1	*	*	*	*	2		
0192	P	0		5910-189-5518	CAPACITOR, FIXED, PAPER DIELECTRIC	21387 SKY2433	EA	1	3	5	10	120	20		
0193	P	0		5340-675-5753	CLIP, RETAINING: FULCRUM PIN	21387 T1498	EA	1	2	2	3	40	10		
0194	P	0		2920-294-4001	COIL, MAGNETO	82796 D2477A	EA	1	2	2	3	40	25		
0195	P	0		2920-319-5055	CONTACT SET, DISTRIBUTOR	21387 A2437A	EA	8	17	33	400	100	100		
0196	P	0		2920-510-1298	GASKET: END CAP	21387 K2498	EA	1	8	17	33	400	100		
0197	P	0		2920-517-0618	GEAR, HELICAL: IMPULSE COUPLING DRIVE	66289 GD87B	EA	1	*	*	2	8	5		
0198		0		5310-737-2632	NUT, CASTELLATED, HEXAGON: IMPULSE COUPLING TO SHAFT RETAINING	21387 M2570	EA	1	*	*	*	*	*		
0199		0		5305-984-6189	SCREW, MACHINE: CAPACITOR MTG	96906 MS35206-241	EA	1	*	*	*	*	*		
0200		0		5305-012-1832	SCREW, MACHINE: CONTACT SET	02032 JHP13-402	EA	1	*	*	*	*	*		
0201		0		5305-013-1885	SCREW, MACHINE: CONTACT SET	12440 3103657	EA	1	*	*	*	*	*		
0202		0		5305-272-5306	SCREW, MACHINE: CONTACT SET	24617 1326969	EA	1	*	*	*	*	*		
0203	P	0		2920-354-0741	SPRING, SPIRAL, TORSION: COUPLING DRIVE	21387 D2565	EA	1	*	*	2	8	5		
0204		0		5310-637-3348	WASHER, FLAT: STATIONARY CONTACT SUPPORT SCREW	43999 2W1-11-12-20	EA	1	*	*	*	*	*		
0205		0		5310-366-7180	WASHER, FLAT: SUPPORT PLATE SCREW	21387 D2458	EA	1	*	*	*	*	*		
0206		0		5310-045-3289	WASHER, LOCK: CAPACITOR MTG	96906 MS35388-42	EA	1	*	*	*	*	*		
0207		0		5310-045-3299	WASHER, LOCK: CONTACT SET	96906 MS35388-42	EA	1	*	*	*	*	*		
0208		0		5310-013-1044	WASHER, LOCK: CONTACT SET	02032 JHP13-430	EA	1	*	*	*	*	*		
0209	X2	0		2920-366-7182	WIRE, LOCK: IMPULSE COUPLING NUT	21387 A5931A	EA	1	*	*	*	*	*		
0210	P	0		2920-620-0291	CABLE ASSEMBLY, SPECIAL PURPOSE, ELECTRICAL: SPARK PLUG	66289 YD259	EA	1	*	2	2	20	10		3
0211	P	0		2920-517-9027	SLEEVE, IGNITION TERMINAL: SPARK PLUG	66289 YD109	EA	1	3	5	10	120	50		
0212	X1			2920-047-4530	GASKET: MAGNETO FLANGE (COMPONENT OF GASKET SET, STOCK NO. 2805-397-1748, SEE GROUP 0100)	66289 QD570A	EA	1						2	19
0213	P	0		2920-509-9612	SPARK PLUG: RADIO SHIELDED, 18MM	66289 YD171	EA	1	16	34	67	800	100		

LINE NO.	SOURCE AND RECOV.			FEDERAL STOCK NUMBER	DESCRIPTION	MANUFACTURER'S CODE PART NUMBER	UNIT OF ISSUE	QTY IN	INC PACK	QTY IN	INC UNIT	30-DAY DS/GS MAINT. ALW.			1-YR. ALW. PER 100 EQUIP. CTNGCY. PLANNING	DEPOT MAINT. ALW. PER. 100 EQUIP.	ILLUS-TRATION	
	(A)	(B)	(C)									(A)	(B)	(C)			(A)	(B)
0214	P	O		5330-467-3553	GASKET: SPARK PLUG, 18 MM, SOLID COPPER	79150 2106A	EA			1		4	8	17	200	*		
0215		O		5306-019-3484	BOLT, MACHINE: MAGNETO MTG	24617 193484	EA			1		*	*	*	*	*	2	16
0216		O		5310-582-5615	NUT, PLAIN, HEXAGON: MAGNETO MTG	96906 MS35690-522	EA			2		*	*	*	*	*	2	18
0217		O		5307-405-9938	STUD, PLAIN: MAGNETO MTG	24617 272962	EA			1		*	*	*	*	*	2	15
0218		O		5310-013-8538	WASHER, LOCK: MAGNETO MTG	24617 138538	EA			2		*	*	*	*	*	2	17
0219					GROUP 22 - BODY, CHASSIS OR HULL AND ACCESSORY ITEMS													
0220					2202 - ACCESSORY ITEMS													
0221	X2	O		4940-672-4764	BOX ASSEMBLY: PRESSURE PUMP BUMPER: RUBBER, PUMPING ASSEMBLY	05748 12189SA	EA			1		*	*	*	*	*		
0222	X2	O		5340-672-1926	CARRYING HANDLE U/O BARNES MODEL 15671CA PUMPING ASSEMBLY)	05748 15363	EA			2		*	*	*	*	*		
0223	X2	O		5340-672-1927	GRIP, HANDLE: PUMPING ASSEMBLY CARRYING HANDLE (U/O BARNES MODEL 15671CA PUMPING ASSEMBLY)	12505 B1B10-5-0	EA			2		*	*	*	*	*		
0224		O		5310-012-0614	NUT, PLAIN, HEXAGON	96906 MS35650-102	EA			2		*	*	*	*	*		
0225	X2	O		5975-577-8825	ROD: GROUND	05748 15675	EA			1		*	*	*	*	*		
0226		O		5305-559-9202	SCREW, CAP, HEXAGON HEAD: BOX MTG	96906 MS35297-3	EA			4		*	*	*	*	*		
0227		O		5305-993-1848	SCREW, MACHINE	96906 MS35207-265	EA			2		*	*	*	*	*		
0228		O		5310-582-5965	WASHER, LOCK: BOX MTG	96906 MS35338-044	EA			4		*	*	*	*	*		
0229	M	O		4940-672-4771	WIRE ASSEMBLY: W/FITTINGS,GROUND MANUFACTURE FROM:	05748 K676A	EA			1								
0229A	X2	O			CLAMP: WIRE TO ROD	05748 15877	EA			1		*	*	*	*	*		
0229B	X2	O			LUG: CLAMP TYPE, GROUND WIRE	05748 15878	EA			1		*	*	*	*	*		
02290	P	O		6145-519-2833	WIRE, ELECTRICAL	05748 15876	FT											
0230					GROUP 55 - PUMPS													
0231					5500 - PUMP ASSEMBLY													
0232		O		5306-225-9081	BOLT, MACHINE	96906 MS35297-036	EA			2		*	*	*	*	*		
0233		O		4730-735-4389	CROSS: PRESSURE PUMP OUTLET	01400 115-33	EA			1		*	*	*	*	*		
0234	P	O		4320-360-0601	GASKET SET: BODY TO INTERMEDIATE COUPLING C/O THE FOLLOWING ITEMS:	05748 8121SA	EA			1		2	2	3	40	100	7	13
0235		O		5310-012-0376	NUT, PLAIN, HEXAGON	96906 MS35690-505	EA			2		*	*	*	*	*		
0236	P	O	R	4320-360-0608	PUMP ASSEMBLY: W/O ENGINE	05748 164185A	EA			1		*	*	*	5	5	2	
0237		O		5310-012-0214	WASHER, LOCK	96906 MS35338-26	EA			2		*	*	*	*	*		
0238	X1				GASKET: 1/32 IN. THK	05748 8021	EA			1								
0239	X1				GASKET: 1/64 IN. THK	05748 8030	EA			2								



LINE NO.	(1) SOURCE, MAINT. AND RECOV. CODE			(2) FEDERAL STOCK NUMBER	(3) DESCRIPTION	(4) MANUFACTURER'S CODE	(5) PART NUMBER	(6) UNIT OF ISSUE	QTY INC	INC	(7) 30-DAY MAINT. DS/GS			(8) 1-YR. ALW. PER 100 EQUIP. CTNGCY. PLANNING	(9) DEPOT MAINT. ALW. PER. 100 EQUIP.	(10) ILLUS-TRATION (A) FIG. NO.	
	(A)	(B)	(C)								(A)	(B)	(C)				
0240	P	0		4320-360-0599	GASKET: SUCTION CHECK VALVE	05748	8026	EA			1	2	3	7	80	100	
0241		0		4730-021-9307	PLUG, PIPE: DRAIN, SQ HEAD	24617	219307	EA			1	*	*	*	*	*	7
0242					5501 - SHAFT, ROTORS, IMPELLERS												
0243	P	0		4320-360-0598	IMPELLER	05748	8023	EA			1	*	2	2	12	5	7
0244	P	0		4320-360-0597	SEAL ASSEMBLY: INTERMEDIATE COUPLING	05748	8022	EA			1	*	2	2	20	10	7
0245	P	0		4320-360-0602	SHIM SET: IMPELLER	05748	8139SA	EA			1	*	2	2	16	10	7
0246	X1				SHIM: .010 THK	05748	8053	EA			2						
0247	X1				SHIM: .031 THK	05748	8054	EA			1						
0248					5505 - SUCTION AND/OR DISCHARGE ASSEMBLY												
0249	X2	0		4320-360-0587	FLANGE: SUCTION HOSE	05748	15669	EA			1	*	*	*	*	*	7
0250	X2	0		4320-360-0583	NIPPLE, PIPE: DISCHARGE TEE (NOT REQUIRED WHEN FSN 4730-735-4389 CROSS IS USED)	05748	3350	EA			1	*	*	*	*	*	7
0251		0		5310-012-0377	NUT, PLAIN, HEXAGON: FLANGE MTG	96906	MS35690-605	EA			3	*	*	*	*	*	
0252		0		5307-360-0580	STUD: FLANGE	05748	2418	EA			3	*	*	*	*	*	7
0253	P	0		4320-377-6981	SUCTION STUB ASSEMBLY: ALUMINUM, DRUM UNLOADER	05748	8215SA	EA			1	*	*	*	5	2	
0254	P	0		4320-360-0600	VALVE ASSEMBLY: CHECK, SUCTION	05748	8117SA	EA			1	*	2	2	16	5	7
0255	X2	0		4320-360-0596	CHAIN: W/S HOODS, STUB	81718	H6683M	EA			1	*	*	*	*	*	8
0256	X2	0		4320-360-0604	COUPLER: ELBOW, FEMALE, STUB	81718	633H11-2	EA			1	*	*	*	*	*	8
0257	X2	0		5340-816-4368	PLUG, PROTECTIVE, DUST: DUST, STUB	81718	634A11-2	EA			1	*	*	*	*	*	8
0258	X2	0		4320-360-0603	TUBE: STUB	81718	249G8	EA			1	*	*	*	*	*	8
0259		0		4730-360-0578	CAP: NOZZLE	81718	HB1461	EA			2	*	*	*	*	*	9
0260		0		4730-360-0572	CAP: W/CHAIN AND SPRING, SPOUT	81718	296C115-8	EA			2	*	*	*	*	*	9
0261	P	0		4930-360-0569	NOZZLE, FUEL AND OIL SERVICING: PRESSURE PUMP DISCHARGE HOSE	81718	CC21011-2	EA			2	*	2	2	20	10	9
0262	P	0		4930-904-1383	PARTS KIT, FUEL AND OIL SERVICING NOZZLE: DISCHARGE HOSE C/O THE FOLLOWING ITEMS:	81718	H4126	EA			2	*	2	2	20	10	
0263	P	0		4730-360-0571	SPOUT: NOZZLE	81718	29611-2X15-8	EA			2	*	2	2	12	5	9
0264	X1				DISC: LOWER	81718	H502M	EA			1						
0270	X1				PACKING	81718	H714M	EA									
0271	X1				PACKING NUT	81718	H113RA	EA			1						
0272	X1				POPPET	81718	C838M	EA			1						
0273	X1				POPPET, SUB-ASSEMBLY, MAIN	81718	H4682	EA			1						
0274					5510 - INLET AND OUTLET COMPONENTS												
0275	X2	0		4730-360-0592	COUPLING HALF, QUICK DISCONNECT: PRESSURE PUMP SUCTION HOSE, 1 1/2 IN.	96906	MS27021-9	EA			2	*	*	*	*	*	
0276	X2	0		4320-360-0594	CAP: FEMALE, DUST, PRESSURE PUMP DISCHARGE AND SUCTION	81718	634B11-2	EA			8	*	*	*	*	*	

LINE NO.	(1) SOURCE, MAINT. AND RECOV.			(2) FEDERAL STOCK NUMBER	(3) DESCRIPTION	(4) MANUFACTURER'S CODE PART NUMBER	(5) UNIT OF ISSUE	(6) QTY INC IN UNIT	(7) 30-DAY DS/GS MAINT. ALW.			(8) 1-YR. ALW. PER 100 EQUIP. CTNGCY. PLANNING	(9) DEPOT MAINT. ALW. PER. 100 EQUIP.	(10) ILLUSTRATION			
	(A) SOURCE	(B) MAINT.	(C) RECOV.						(A) 1-20	(B) 21-50	(C) 51-100			(A) FIG. NO.	(B) ITEM OR SYM. NO.		
0277	P	O		4320-360-0596	CHAIN: W/S HOOKS, PRESSURE PUMP SUCTION AND DISCHARGE DUST CAP	81718 H6683M	EA		8	*	2	2	12		8		
0278		O		4730-494-0871	CLAMP, HOSE: PRESSURE PUMP, DISCHARGE AND SUCTION HOSE	77414 16	EA		16	*	*	*	*		*		
0279	P	O		4940-360-0711	COUPLER: FEMALE, PRESSURE PUMP DISCHARGE TEE, MALE THREAD	81718 633B11-2	EA		1	*	*	2	8		3		
0280	X2	O		4730-360-0589	COUPLING HALF, QUICK DISCONNECT: PRESSURE PUMP SUCTION AND DISCHARGE HOSE	81718 633F11-2	EA		5	*	*	*	*		*		
0281	P	O		4320-360-0591	COUPLING HALF, QUICK DISCHARGE: W/SHANK, FEMALE, PRESSURE PUMP DISCHARGE AND SUCTION HOSE	81718 633C11-2	EA		6	*	2	2	12		5		
0282	P	O		4320-360-0595	GASKET: KAMLOCK TYPE, DISCHARGE AND SUCTION HOSE COUPLER	81718 H6430M	EA		14	2	3	7	80		100		
0283	P	O		4720-303-4984	HOSE ASSEMBLY: DISCHARGE	05748 15656SA	EA		2	*	2	2	12		5		
0283A	P	O		4720-555-8325	HOSE ASSEMBLY, RUBBER	05748 1567SA	EA		1	*	*	2	6		5		
0284	P	O		4320-360-0593	PLUG, PROTECTIVE, DUST: MALE, DUST PRESSURE PUMP DISCHARGE AND SUCTION HOSE COUPLER	81718 634A11-2	EA		7	2	2	3	40		100		
0285	X2	O			TEE, PIPE: SIDE OUTLET, PRESSURE PUMP DISCHARGE (REPLACED BY FSN 4730-735-4389 CROSS)	63686 7119-1-1-2	EA		1	*	*	*	*		*		
0286					5511 - COUPLINGS												
0287	X2	O		4320-360-0586	COUPLING: INTERMEDIATE, PUMP TO ENGINE	05748 5364	EA		1	*	*	*	*		*	7	15
0288		O		5310-012-0377	NUT, PLAIN, HEXAGON	96906 MS35690-605	EA		10	*	*	*	*		*		
0289		O		5305-269-3214	SCREW, CAP, HEXAGON HEAD	96906 MS90725-64	EA		4	*	*	*	*		*		
0290		O		5307-360-0579	STUD: INTERMEDIATE COUPLING	05748 2417	EA		6	*	*	*	*		*	7	12
0291		O		5310-012-0382	WASHER, LOCK	24617 120382	EA		4	*	*	*	*		*		
0301					GROUP 95 - GENERAL USE STANDARDIZED PARTS												
0302					9501 - HARDWARE SUPPLIES AND BULK MATERIAL, COMMON												
0303	P	F		4710-277-5525	TUBING, COPPER		FT			*	*	*	5		5		
0304	P	O		6145-519-2833	WIRE, ELECTRICAL	05748 15876	FT			2	4	8	100		100		

LINE NO.	(1) SOURCE, MAINT. AND RECOV. CODE			(2) FEDERAL STOCK NUMBER	(3) DESCRIPTION	(4) MANUFACTURER'S CODE	(5) UNIT OF ISSUE	(6) QTY INC IN UNIT	(7) 30-DAY DS/GS MAINT. ALW.			(8) 1-YR. ALW. PER 100 EQUIP. CTNGCY. PLANNING	(9) DEPOT MAINT. ALW. PER. 100 EQUIP.	(10) ILLUS-TRATION (A) FIG. NO.	
	(A)	(B)	(C)						(A)	(B)	(C)				
	SOURCE	MAINT.	RECOV.						1-20	21-50	51-100				
0306					SECTION VI - SPECIAL TOOLS, TEST AND SUPPORT EQUIPMENT FOR DS, GS, AND DEPOT MAINTENANCE										
0307					GROUP 26 - TOOLS AND TEST EQUIPMENT										
0308					2604 - SPECIAL TOOLS										
0309					NOTE: IF THESE TOOLS ARE NOT COMPONENTS OF AUTHORIZED TO & E TOOL SET, ONE EACH IS AUTHORIZED PER USING UNIT.										
0310	P	O		5120-359-6587	CLAMPING TOOL, STRAP ASSEMBLY C/O THE FOLLOWING ITEMS:	77414	P38	EA	1	*	*	*	*	*	
0311	X1				FRAME	77414	D285A	EA	1						
0312	X1				PUNCH AND WINDER	77414	D289A	EA	1						
0313	X1				WINDER	77414	D290F	EA	1						
0314	X1				WRENCH: RATCHET	77414	D298A	EA	1						

INDEX TO PARTS, FIGURE 1

REF NO.	FUNCT GROUP	ITEM NAME
1	0101	BOLT
2	0101	BOLT
3	0101	WASHER
4	0101	WASHER
5	0101	HEAD
6	0101	GASKET
7	0101	PLUG
8	0101	PLUG
9	0101	PLUG
10	0101	GASKET
11	0101	PLUG
12	0101	SCREW
13	0101	WASHER
14	0105	WASHER
15	0105	SCREW
16	0304	SCREW
17	0304	WASHER
18	0304	STRAP
19	0304	ELEMENT
20	0304	SCREW

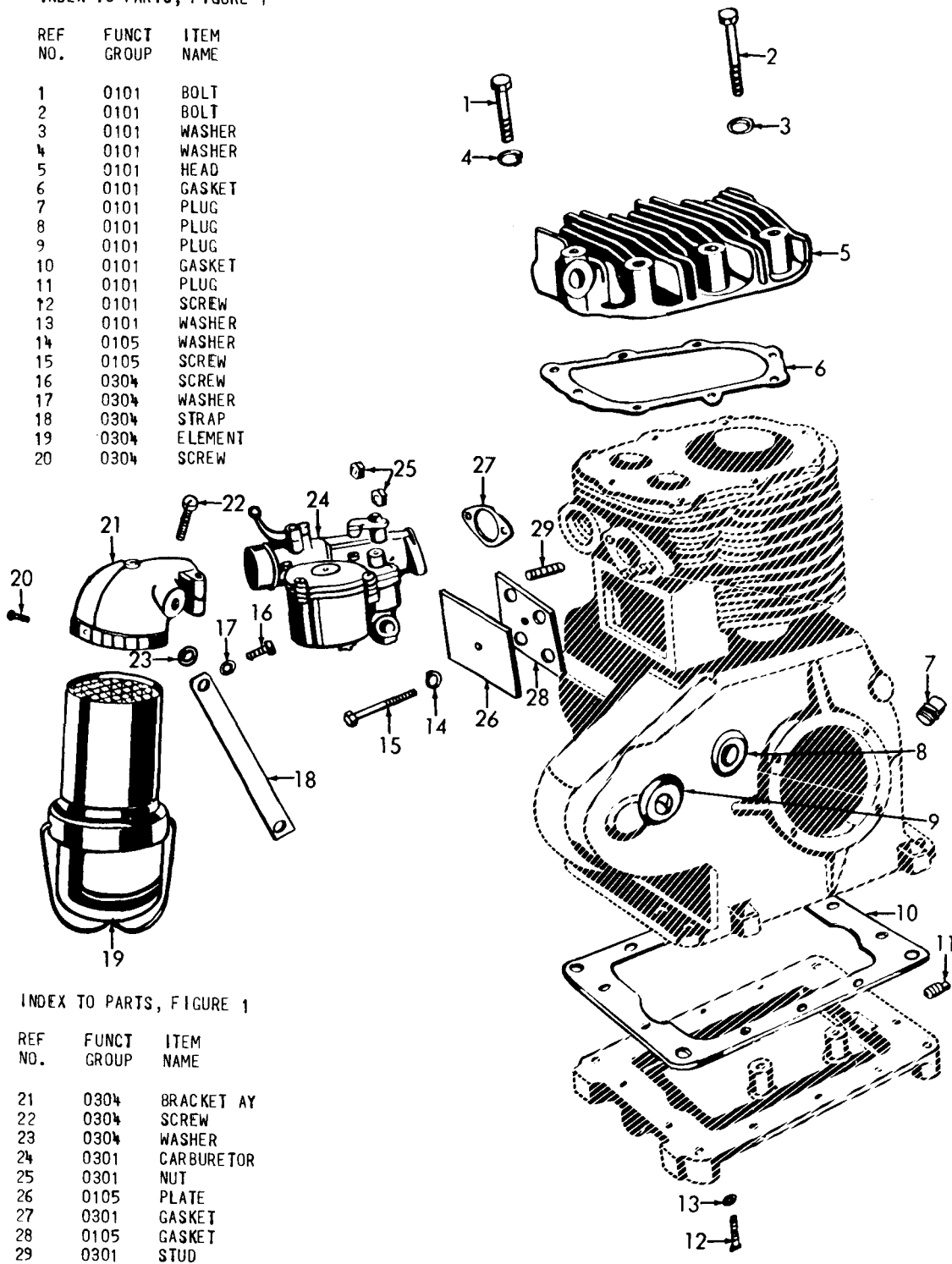

INDEX TO PARTS, FIGURE 1

REF NO.	FUNCT GROUP	ITEM NAME
21	0304	BRACKET AY
22	0304	SCREW
23	0304	WASHER
24	0301	CARBURETOR
25	0301	NUT
26	0105	PLATE
27	0301	GASKET
28	0105	GASKET
29	0301	STUD

MEC 4320-202-25P/1

Figure 1. Cylinder Head; Cylinder, Carburetor; Air Cleaner.

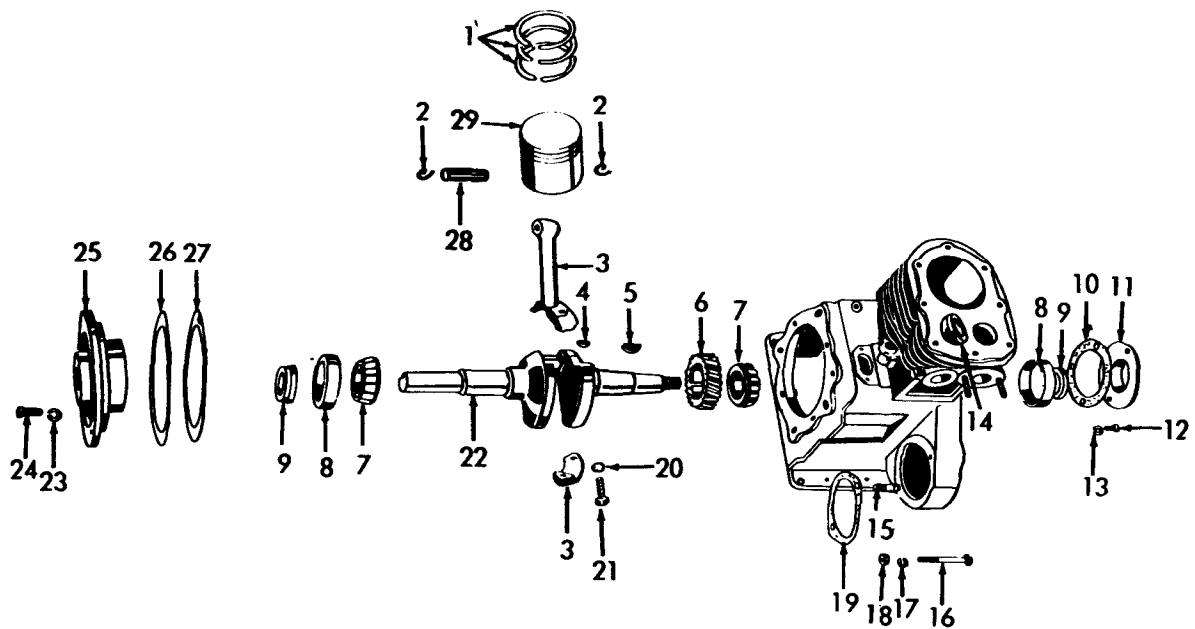

MEC 4320-202-25P/2

Figure 2. Piston, Connecting Rod; Cylinder; Crankshaft.

INDEX TO PARTS, FIGURE 2

REF NO.	FUNCT GROUP	ITEM NAME	REF NO.	FUNCT GROUP	ITEM NAME	REF NO.	FUNCT GROUP	ITEM NAME
1	0104	RING SET	11	0102	PLATE AY	21	0104	BOLT
2	0104	RING	12	0102	SCREW	22	0102	CRANSHAFT AY
3	0104	CONNECTING ROD	13	0102	WASHER	23	0102	WASHER
4	0102	KEY	14	0105	SEAT	24	0102	BOLT
5	0103	KEY	15	0605	STUD	25	0102	PLATE AY
6	0102	GEAR	16	0605	BOLT	26	0102	GASKET
7	0102	CONE-ROLLERS	17	0605	WASHER	27	0102	GASKET
8	0102	CUP	18	0605	NUT	28	0104	PIN
9	0102	GASKET	19	0605	GASKET	29	0104	PISTON
10	0102	GASKET	20	0104	WASHER			

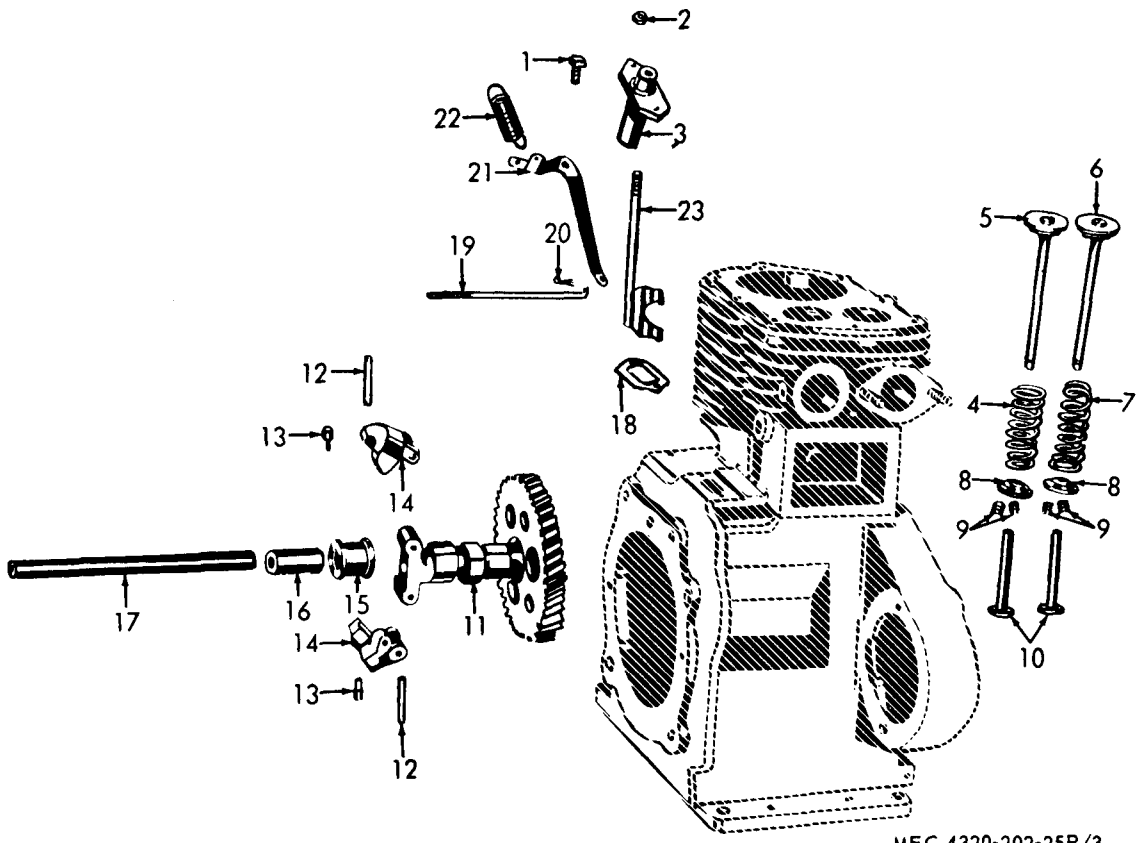

MEC 4320-202-25P/3

Figure 3. Governor, Valves; Camshaft.

INDEX TO PARTS, FIGURE 3

REF NO.	FUNCT GROUP	ITEM NAME	REF NO.	FUNCT GROUP	ITEM NAME
1	0308	SCREW	13	0308	PIN
2	0308	NUT	14	0308	FLYWEIGHT
3	0308	BRACKET	15	0308	BEARING
4	0105	SPRING	16	0308	SPACER
5	0105	VALVE	17	0105	PIN
6	0105	VALVE	18	0308	GASKET
7	0105	SPRING	19	0308	BOLT
8	0105	SEAT	20	0308	PIN
9	0105	LOCK	21	0308	LEVER
10	0105	LIFTER	22	0308	SPRING
11	0105	CAMSHAFT AY	23	0308	YOKE
12	0308	PIN			

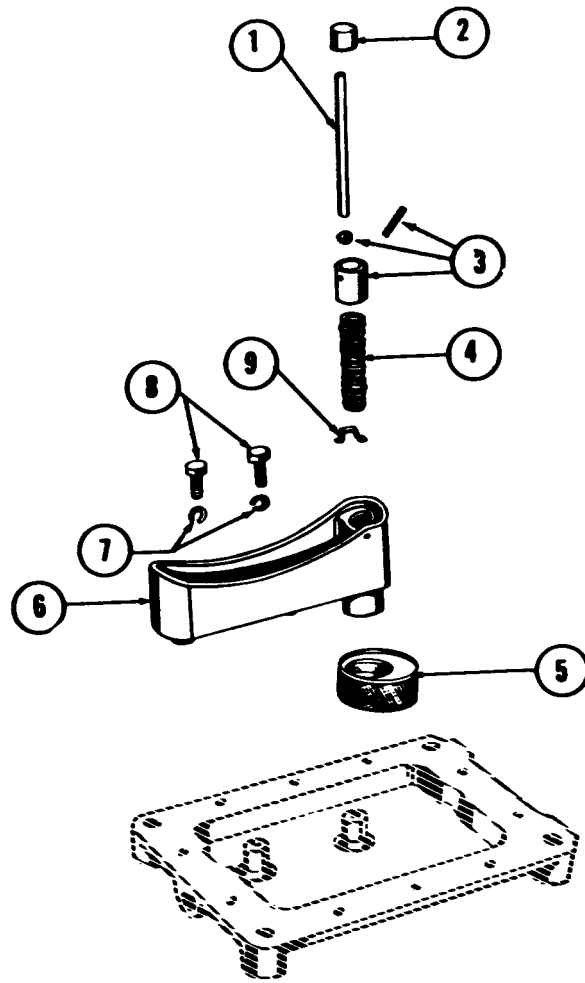

MEC 4320-202-25P/4

Figure 4. Oil Pump.

INDEX TO PARTS, FIGURE 4

REF NO.	FUNCT GROUP	ITEM NAME
1	0106	ROD
2	0106	CAP
3	0106	PLUNGER AY
4	0106	SPRING
5	0106	STRAINER
6	0106	BODY
7	0106	WASHER
8	0106	SCREW
9	0106	RETAINER

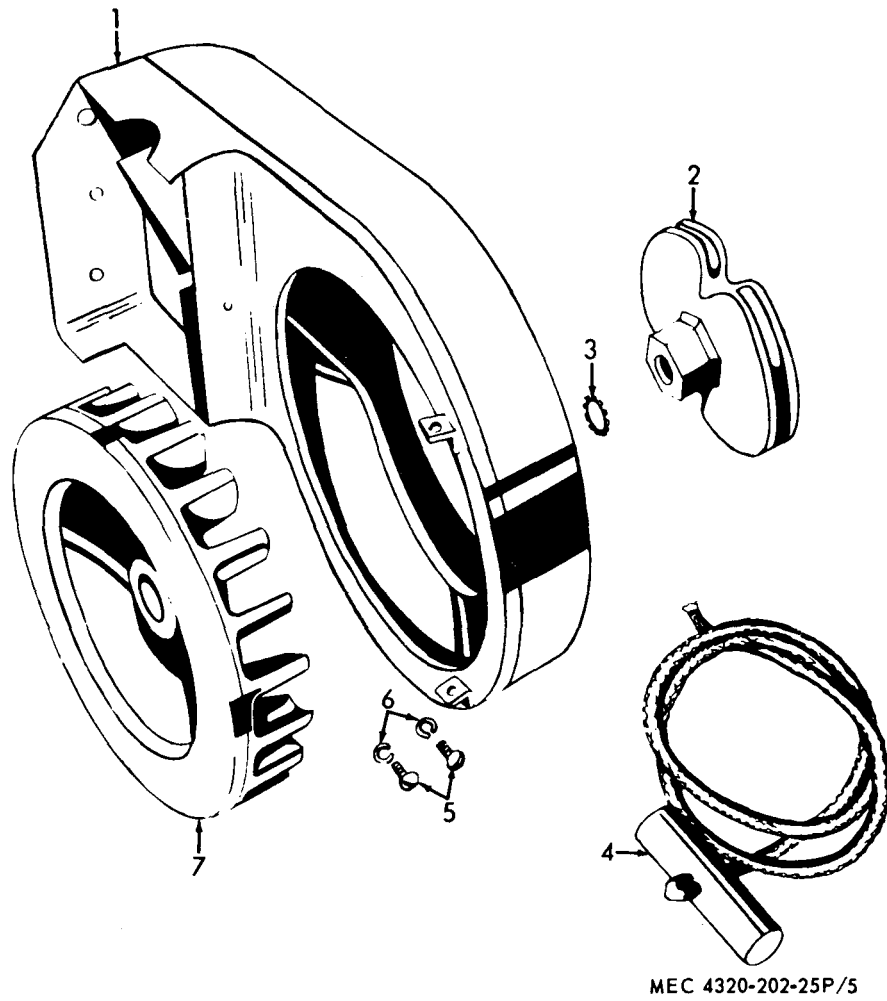

MEC 4320-202-25P/5

Figure 5. Air Shroud; Flywheel; Pulley; Rope.

INDEX TO PARTS, FIGURE 5

REF NO.	FUNCT GROUP	ITEM NAME
1	0502	SHROUD AY
2	0107	PULLEY
3	0107	WASHER
4	0107	STARTER ROPE
5	0502	SCREW
6	0502	WASHER
7	0103	FLYWHEEL



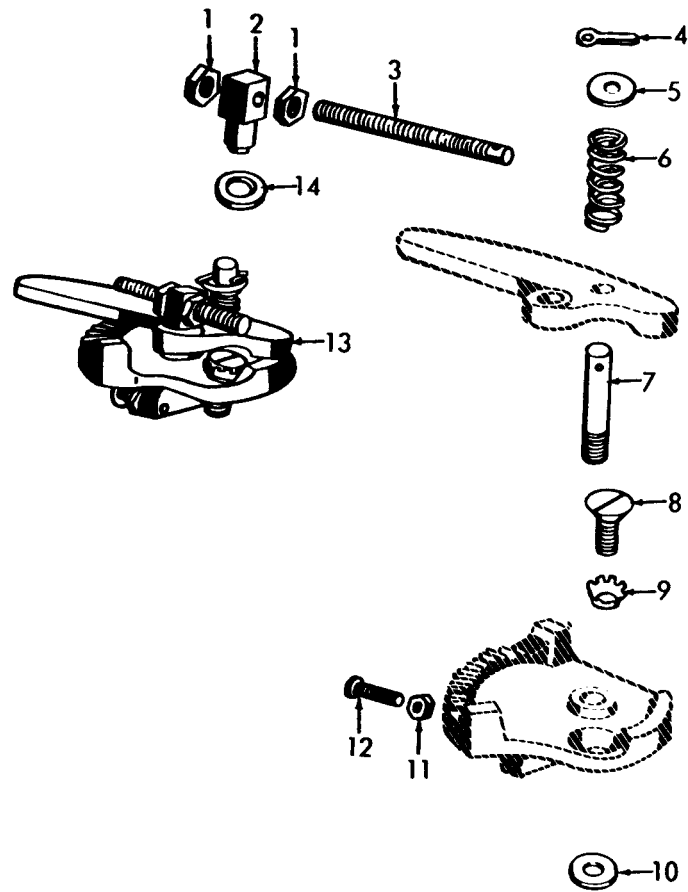

MEC 4320-202-25P/6

Figure 6. Speed Control.

INDEX TO PARTS, FIGURE 6

REF NO.	FUNCT GROUP	ITEM NAME	REF NO.	FUNCT GROUP	ITEM NAME
1	0308	NUT	8	0308	SCREW
2	0308	BLOCK	9	0308	WASHER
3	0308	PIN	10	0308	WASHER
4	0308	PIN	11	0308	NUT
5	0308	WASHER	12	0308	SCREW
6	0308	SPRING	13	0308	CONTROL AY
7	0308	PIN	14	0308	WASHER

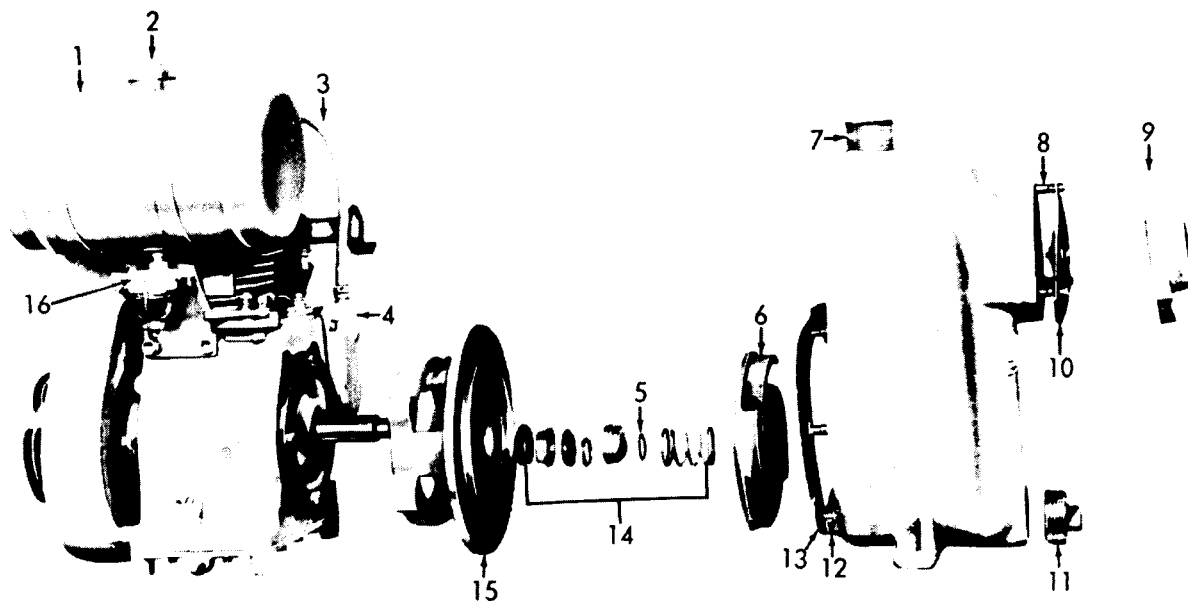

MEC 4320-202-25P/7

Figure 7. Pressure Pump; Engine.

INDEX TO PARTS, FIGURE 7

REF NO.	FUNCT GROUP	ITEM NAME	REF NO.	FUNCT GROUP	ITEM NAME
1	0306	TANK AY	9	5505	FLANGE
2	0306	CAP	10	5505	VALVE AY
3	0605	CABLE AY	11	5500	PLUG
4	0605	MAGNETO	12	5511	STUD
5	5501	SHIM SET	13	5500	GASKET SET
6	5501	IMPELLER	14	5501	SEAL AY
7	5505	NIPPLE	15	5511	COUPLING
8	5505	STUD	16	0309	STRAINER

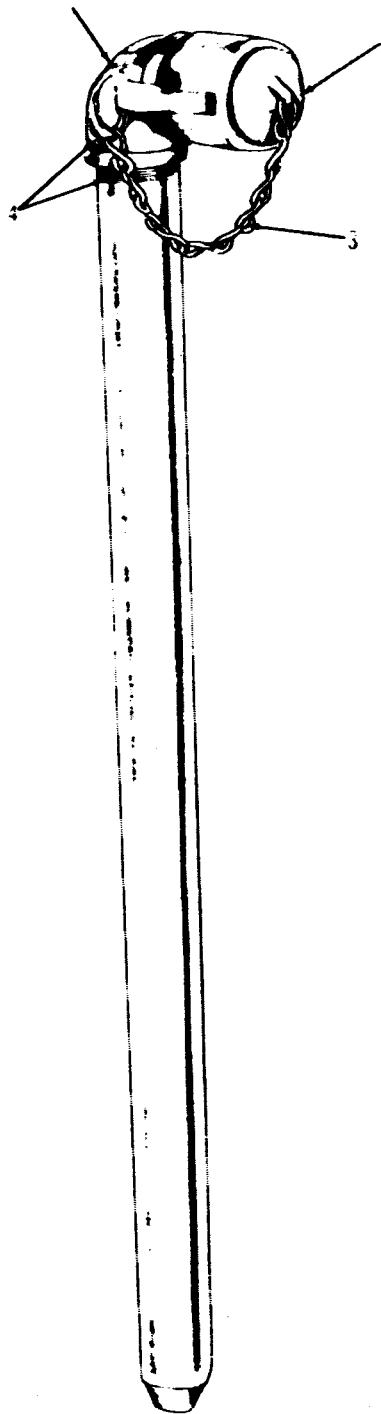

INDEX TO PARTS, FIGURE 8

REF NO.	FUNCT GROUP	ITEM NAME
1	5505	COUPLER
2	5505	PLUG
3	5505	CHAIN
4	5505	TUBE

MEC 4320-201-25P. 14

Figure 8. Suction Stub.

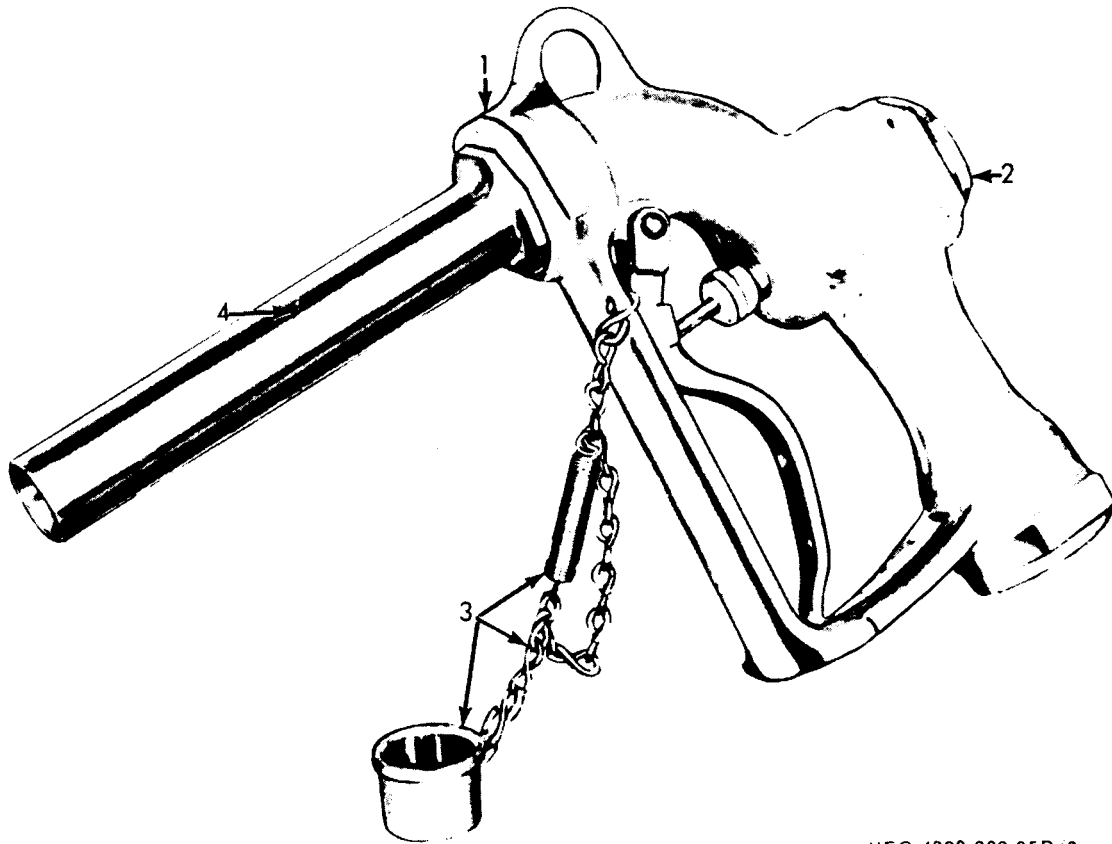

MEC 4320-202-25P/9

Figure 9. Nozzle Assembly.

INDEX TO PARTS, FIGURE 9

REF NO.	FUNCT GROUP	ITEM NAME
1	5505	NOZZLE
2	5505	CAP
3	5505	CAP
4	5505	SPOUT

FEDERAL STOCK NUMBER AND PART NUMBER INDEX

NUMBER	CODE	PAGE	NUMBER	CODE	PAGE	NUMBER	CODE	PAGE
AB99P2	66289	001	KF19A	66289	011	MS35756-6	96906	010
		009	KF22	66289	012			011
AE74C	66289	011	K2498	21387	004	MS9048-171	96906	013
AE74D	66289	011			015	MS90725-12	96906	002
AF43	66289	11	K676A	05748	005			011
AF49A	66289	011			016	MS90725-28	96906	002
AG26	66289	011	LO-31A	66289	001			013
AG31	66289	011			009	MS90725-3	96906	010
AH9	66289	011	MILB6986TYPEA	81349	001			013
A2437A	21387	004			009	MS90725-6	96906	010
		015	MS15795-210	96906	002	MS90725-64	96906	007
A5931A	21387	005			003			018
		015			012	MS90725-8	96906	004
BG170S1	66289	010			014			014
BG171S1	66289	010	MS15795-212	96906	001	M2570	21387	004
BKND162685	66289	001			010			015
		009	MS24665-69	96906	003	NC137	66289	010
BK71	66289	002			013	PA264	66289	011
		013	MS27021-9	96906	007	PC368	66289	002
B1B10-5-0	12505	005			017			012
		016	MS27183-6	96906	003	PC393-2	66289	003
B1264BS1	66289	002			014			014
		012	MS35026-279	96906	004	PE82	66289	011
CA51-88S1	66289	010			015	PF102	66289	001
CC21011-2	81718	006	MS35206-241	96906	004			011
		017			015	PG287	66289	002
C838M	81718	007	MS35206-283	96906	002			012
		017			012	PG733	66289	002
DA70BS1	66289	011	MS35206-286	96906	002			013
DE68S5	66289	11			013	PH221	66289	003
DP4	66289	011	MS35207-265	96906	005			014
DR30	66289	011			016	PH254	66289	010
D2458	21387	004	MS35297-036	96906	001	PH256	66289	010
		015			006	PH30	66289	002
D2477A	82796	004			009			011
		015			016	PH30A	66289	010
D2565	21387	004	MS35297-3	96906	005	PH412	66289	010
		015			016	PI121	66289	003
D285A	77414	008	MS35297-32	96906	010			014
		019	MS35297-40	96906	001	PK50	66289	012
D289A	77414	008			009	PK69	66289	011
		019	MS35301-36	96906	011	PM117	66289	003
D290F	77414	008	MS35335-25	96906	002			014
		019			012	PM58	66289	012
D298A	77414	008	MS35338-004	96906	004	PM74	66289	003
		019			014			013
EA101DS1	66289	011	MS35338-044	96906	003	P38	77414	008
FA42A	66289	011			004			019
FFP386TYPEB	81348	003			005	QC53	66289	001
		013			010			002
FMXDE1B7U	21387	004			012			009
		015			013			012
GA34A	33289	010			013	QD569A	66289	009
GD87B	66289	004			015			009
		015			016	QD570A	66289	001
G2788	21387	004	MS35338-26	96906	001			005
		015			006			009
HB1461	81718	006			010			015
		017			016	QD571	66289	001
HG201D	66289	011	MS35388-42	96906	004			009
H113RA	81718	007			005			013
		017			015	QD572	66289	009
H4126	81718	006			015			011
		017	MS35648-4	96906	009	QD573	66289	009
H4682	81718	007	MS35650-101	96906	003			010
		017			013	QD573A	66289	009
H502M	81718	006	MS35650-102	96906	005			010
		017			016	QD574	66289	001
H6430M	81718	007	MS35690-425	96906	002			009
		018			003			010
H6683M	81718	006			012	QD604A	74340	001
		007			013			001
		017	MS35690-505	96906	006			009
		018			016			009
H714M	81718	007	MS35690-522	96906	005	QD647	66289	002
		017			016			012
JHP13-402	02032	004	MS35690-605	96906	001	QD694	66289	002
		015			006			013
JHP13-430	02032	005			007	Q2	66289	001
		015			009			009
KA59B1S1	66289	011			017	RC104	66289	002
KF14S1	66289	011			018			013

FEDERAL STOCK NUMBER AND PART NUMBER INDEX

NUMBER	CODE	PAGE	NUMBER	CODE	PAGE	NUMBER	CODE	PAGE
RD107	66289	012	15250	60038	010	2805-358-2303		010
RP902	66289	013	15363	05748	005	2805-358-3077		010
SA61	66289	001			016	2805-376-0382		011
		011	15656SA	05748	007	2805-376-0385		001
SA80	66289	011			018			011
SE53AS1	66289	004	15664	05748	004	2805-376-0395		010
		015			014	2805-376-0398		009
SXY2433	21387	004	15669	05748	006			009
		015			017	2805-376-0416		001
TC301-3	66289	003	1567SA	05748	007			011
		013			018	2805-376-0417		011
TC321	66289	013	15675	05748	005	2805-376-0419		012
TC322	66289	013			016	2805-396-0853		012
TC323	66289	013	15876	05748	005	2805-397-1748		001
TC324C	66289	013			007			009
TC325	66289	013			016	2805-428-2094		011
TC328D	66289	013			018	2805-447-9294		011
TC332	66289	003	15877	05748	005	2805-448-1050		011
		013			016	2805-505-5191		011
T1498	21387	004	15878	05748	005	2805-555-2119		011
		015			016	2805-630-1110		011
T1802D	76700	004	16	77414	007	2805-672-1918		001
		014			018			009
UC103A	66289	002	16-14	96152	012	2805-672-1922		001
		012	16-4	96152	012			009
U218A	66289	002	16-638	96152	012	2805-672-9509		011
		012	16A83	96152	012	2805-696-0040		011
VE304	66289	003	16A95	96152	012	2805-776-8151		011
		013	16418SA	05748	004	2910-049-3711		012
VE363A	66289	003			014	2910-215-7236		013
		013	164185A	05748	006			
VH53	96152	002			016			
		012	179504	00000	003	2910-255-2308		002
WE14G	66289	003			014			012
		013	180020	81336	002	2910-282-7557		003
XK2A	66289	001			012			014
		010	180022	81366	012	2910-358-4316		003
YD109	66289	005	180134	24617	001			014
		015			009	2910-358-4317		003
YD171	66289	005	193484	24617	005			014
		015			016	2910-358-5327		003
YD259	66289	005	2W1-11-12-20	43999	004			014
		015			015	2910-364-4996		012
0W480T	78480	003	205-01-17	19315	002	2910-447-9260		002
		014			013			012
0705	78480	003	20501-17	19315	004	2910-464-3530		002
		014			014			013
07759	78480	003	2106A	79150	005	2910-672-1914		002
		014			016			013
07762	78480	003	219307	24617	006	2910-672-1915		003
		014			017			013
07766	78480	003	219678	24617	004	2910-672-1916		002
		014			014			013
08227	78480	003	233-536	96152	012	2920-047-4530		001
		014	2417	05748	007			005
103885	24617	001			018			009
		009	2418	05748	006			015
108687	24617	004			017	2920-294-4001		004
		014	249G8	81718	006			015
115-33	01400	006			017	2920-319-5055		004
		016	25-214554	09348	013			015
115137	81336	002	272962	24617	005	2920-354-0741		004
		012			016			015
118753	24617	002	2805-033-6135		011	2920-354-0750		004
		013	2805-033-6140		001			015
120382	24617	003			009	2920-366-7182		005
		007	2805-143-6657		011			015
		013	2805-147-3739		011	2920-509-9612		005
		018	2805-244-8184		001			015
120585	81366	003			009	2920-510-1298		004
		014			010			015
12189SA	05748	005	2805-249-9903		010	2920-517-0618		004
		016	2805-268-3448		009			015
1326969	24617	004			011	2920-517-9027		005
		015	2805-270-3429		011			015
132764	81366	003	2805-277-2918		011	2920-620-0291		005
		014	2805-301-2940		011			015
138538	24617	005	2805-351-6835		001	2920-654-3499		004
		016			001			015
142868	24617	003			009	2930-384-8485		004
		014			009			015
15118	60038	010	2805-353-5849		010	2940-021-0587		002

FEDERAL STOCK NUMBER AND PART NUMBER INDEX

NUMBER	CODE	PAGE	NUMBER	CODE	PAGE	NUMBER	CODE	PAGE
		012	4730-021-9199		001	5305-559-9202		005
2940-215-7226		002			010			016
		012	4730-021-9307		006	5305-984-6189		004
2940-675-5751		002			017			015
		012	4730-021-9678		004	5305-988-1723		004
2940-888-0990		012			014			015
296C115-8	87178	006	4730-042-6318		001	5305-988-1727		002
		017			009			012
29611-2X15-8	81718	006	4730-189-2729		013	5305-988-9265		002
		017	4730-193-6992		003			013
2990-142-0080		002			014	5305-993-1848		005
		012	4730-230-1996		003			016
2990-224-8188		003			014	5306-018-0081		001
		013	4730-231-5632		002			009
2990-301-6374		003			013	5306-018-0087		001
		013	4730-246-1219		004			009
2990-376-0386		013			014	5306-019-3484		005
2990-376-0394		013	4730-360-0571		006			016
2990-383-9339		003			017	5306-225-9081		006
		013	4730-360-0572		006			016
2990-389-6412		004			017	5306-356-0965		003
		014	4730-360-0578		006			013
2990-422-6161		002			017	5306-550-1642		011
		012	4730-360-0589		007	5306-616-1287		010
2990-511-7629		013			018	5306-672-1923		004
2990-536-2962		003	4730-360-0592		007			014
		013			017	5307-286-0334		002
2990-661-8942		013	4730-494-0871		007			012
3103657	12440	04			018	5307-360-0579		007
		015	4730-622-1607		001			018
3110-100-0522		010			010	5307-360-0580		006
3110-100-3158		010	4730-639-9638		003			017
3350	05748	006			014	5307-405-9938		005
		017	4730-735-4389		006			016
B46503PC1	100001	013			016	5310-012-0214		001
4320-360-0583		006	4930-360-0569		006			006
		017			017			010
4320-360-0586		007	4930-904-1383		006			016
		018			017	5310-012-0367		002
4320-360-0587		006	4940-360-0711		007			003
		017			018			012
4320-360-0591		007	4940-672-4764		005			013
		018			016	5310-012-0376		006
4320-360-0593		007	4940-672-4767		004			016
		018			014	5310-012-0377		006
4320-360-0594		007	4940-672-4768		003			007
		017			014			017
4320-360-0595		007	4940-672-4769		004			018
		018			014	5310-012-0382		001
4320-360-0596		006	4940-672-4771		005			003
		007			016			007
		017	5120-359-6587		008			009
		018			019			013
4320-360-0597		006	5305-011-5137		002			018
		017			012	5310-012-0614		005
4320-360-0598		006	5305-012-0585		003			016
		017			014	5310-012-0622		003
4320-360-0599		006	5305-012-1832		004			014
		017			015	5310-013-1044		005
4320-360-0600		006	5305-013-1885		004			015
		017			015	5310-013-8489		001
4320-360-0601		006	5305-013-2764		003			009
		016			014	5310-013-8502		002
4320-360-0602		006	5305-044-3760		012			012
		017	5305-068-0500		010	5310-013-8538		005
4320-360-0603		006			013			016
		017	5305-068-0502		002	5310-013-8604		003
4320-360-0604		006			010			014
		017			012	5310-021-0377		001
4320-360-0608		006	5305-071-2239		002			009
		016			011	5310-045-3299		004
4320-377-6981		006	5305-225-3839		004			005
		017			012			015
44-51	96152	002			014			015
		012	5305-267-3209		002	5310-082-1404		003
443760	00000	012			013			014
4710-277-5525		013	5305-269-3214		007	5310-176-8139		002
		018			018			004
4720-303-4984		007	5305-269-3218		001			013
		018			009			014
4720-555-8325		007	5305-272-5306		004	5310-190-0743		010
		018			015	5310-193-7407		003

FEDERAL STOCK NUMBER AND PART NUMBER INDEX

NUMBER	CODE	PAGE	NUMBER	CODE	PAGE	NUMBER	CODE	PAGE
		014	5364	05748	007			
5310-285-8538		002			018			
		011	5910-189-5518		004			
5310-290-5759		011			015			
5310-366-7180		004	5975-577-8825		005			
		015			016			
5310-582-5615		005	6145-519-2833		005			
		016			007			
5310-582-5965		003			016			
		004			018			
		004	633A1	81718	003			
		005			014			
		010	633B11-2	81718	007			
		012			018			
		013	633C11-2	81718	007			
		014			018			
		015	633D1	81718	004			
		016			014			
5310-616-3023		001	633F11-2	81718	007			
		010			018			
5310-637-3348		004	633H11-2	81718	006			
		015			017			
5310-675-5755		010	634A11-2	81718	006			
5310-737-2632		004			007			
		010			017			
5310-809-4058		002			018			
		003	634B11-2	81718	007			
		012			017			
		014	7119-1-1-2	63686	007			
5310-833-2080		003			018			
		013	76B1	80749	002			
5315-012-4552		010			012			
5315-221-0480		011	8021	05748	016			
5315-252-5989		003	8022	05748	006			
		013			017			
5315-265-9197		003	8023	05748	006			
		014			017			
5315-383-9335		003	8026	05748	006			
		014			017			
5315-616-5514		010	8030	05748	016			
		011	8053	05748	017			
5315-663-1215		013	8054	05748	017			
5315-687-3787		013	8117SA	05748	006			
5315-828-8190		003			017			
		013	8121SA	05748	006			
5330-141-4906		010			016			
5330-145-2017		003	8139SA	05748	006			
		014			017			
5330-238-7951		002	8215SA	05748	006			
		012			017			
5330-239-1471		001	8630-29-24	08315	003			
		002			014			
		009						
		012						
5330-247-6680		012						
5330-247-6879		012						
5330-266-2701		009						
		010						
5330-285-5061		001						
		009						
		013						
5330-291-7918		012						
5330-298-5170		009						
		010						
5330-298-5744		010						
5330-467-3553		005						
		016						
5330-675-5752		002						
		013						
5340-050-1591		009						
5340-147-3745		012						
5340-250-0098		011						
5340-256-7147		003						
		014						
5340-291-8235		011						
5340-672-1926		005						
		016						
5340-672-1927		005						
		016						
5340-675-5753		004						
		015						
5340-816-4368		006						
		017						



By Order of the Secretary of the Army:

**HAROLD K. JOHNSON**  
*General, United States Army,*  
*Chief of Staff*

Official:

**KENNETH G. WICKHAM,**  
*Major General, United States Army,*  
*The Adjutant General.*

Distribution:

**Active Army:**

USASA (1)	USAMEC (46)
DCSLOG (1)	Svc Colleges (2)
CNGB (1)	Br Svc Sch (2) except
CAR (1)	USAQMS (10)
USAMC (12)	USAQMCENFL (4)
USAWECOM (5)	Fort Knox Fld Maint (10)
USAMICOM (5)	USACDCEC (10)
USAMUCOM (5)	USMA (1)
USAECOM (5)	Army Depots (4)
USATECOM (5)	POE (OS) (2)
USCONARC (2)	USA Tml Cored (2)
CofEngrs (6)	Army Tml (2)
CofSptS (1)	Arsenals (2)
Dir/Trans (1)	PG (2)
OCC-E (1)	Instl (2)
ARADCOM (2)	QM FLDMS (2)
ARADCOM Rgn (2)	Units org under fol TOE:
OS Maj Cored (3)	(2 copies each)
LOGCOMD (1)	10-105
MDW (1)	10-107
Armies (5)	10-445
NLABS (4)	10-448
DPSC (10)	

NG: None

**USAR:** Same as active Army except allowance is one (1) copy for each unit.

For explanation of abbreviations used, see **AR 320-50**.





**TM 10-4320-202-25P PUMP ASSEMBLY 50 GPM-1967**

**PIN: 028376-000**